

# GRUNDIG

## Service Manual

### VIDEO

### GV 819 M



Additionally required  
Service Manuals for the Complete Service

**Service  
Manual**

**GV 819 M**

Part No.  
72010 534 0000

**Service  
Manual**

**Safety**

Part No.  
72010 800 0000

Btx \* 32700 #

Part Number 72010 534 0000

Subject to alteration

Printed in Germany  
VK21/VK211 0998



The regulations and safety instructions shall be valid as provided by the "Safety" Service Manual, part number 72010 800 0000, as well as the respective national deviations.

## GB Table of Contents

	Page
<b>General</b> .....	<b>1-1...1-2</b>
Test Equipment / Aids .....	1-2
Specification .....	1-2
<b>Mechanism Adjustment</b> .....	<b>2-1...2-26</b>
<b>Electrical Adjustment</b> .....	<b>3-1...3-4</b>
<b>Layout of PCB and Circuit Diagrams</b> .....	<b>4-1...4-33</b>
Schematic Diagram Notes .....	4-1
Circuit Board Notes .....	4-2
Board Interconnections .....	4-3
Video/N.Audio Schematic Diagram .....	4-5
On Screen Schematic Diagram .....	4-7
Syscon Schematic Diagram .....	4-9
Switching Regulator Schematic Diagram .....	4-11
Tuner Schematic Diagram .....	4-13
SW/Display Schematic Diagram .....	4-15
Terminal Schematic Diagram .....	4-17
Waveforms .....	4-19
Cap Motor Sub Schematic Diagram and Circuit Board ..	4-20
Main and A/C Head Circuit Board .....	4-21
Grid Assignment .....	4-24
Remote Control Schematic Diagram .....	4-25
Voltage Charts .....	4-27
SYSTEM CONTROL Block Diagram .....	4-29
Video Block Diagram .....	4-31
Audio Block Diagram .....	4-33
<b>Exploded Views and Spare Parts List</b> .....	<b>5-1...5-3</b>

## General

### Test Equipment / Aids

Variable isolating transformer	Colour generator
Dual channel oscilloscope	AF Generator
Digital multimeter	Stabilized power supply
Millivoltmeter	Frequency counter

Please note the Grundig Catalog "Test and Measuring Equipment" obtainable from:

**Grundig Instruments**  
**Test- und Meßsysteme GmbH**  
 Würzburger Str. 150, D-90766 Fürth/Bay.  
 Tel. 0911/703-4118, Telefax 0911/703-4130  
 eMail: [instruments@grundig.de](mailto:instruments@grundig.de)  
 Internet: <http://www.grundig-instruments.de>

	Part no.
Grease .....	75988 034 7400
Torque gauge .....	75981 311 3200
Presetting unit .....	75981 311 2600
Alignment tape .....	75981 311 2700
Back tension cassette gauge .....	75981 311 3300
A/C head positioning tool .....	75981 311 3400
Roller driver .....	75981 311 3500

You can order this test equipment from the Service organization. We refer to you that this test equipment is already obtainable on the market.

## Specification

### VHS-System

$\frac{1}{2}$ " video cassette recorder  
 Tape speed ..... 2.339cm/s (Standard play)  
 Head to tape speed ..... 4.84m/s (Standard play)

### TV standard

CCIR, B/G, DK - PAL, I - PAL, SECAM K1

### Record and playback of tapes with norm

PAL (PAL 60)  
 MESECAM / NTSC (3,58) via A/V socket

### Sound

Input via cinch socket ..... -8dBs, 50k $\Omega$  (0dB = 0.775V<sub>rms</sub>)  
 Output via cinch socket ..... -6dBs, 1k $\Omega$  (0dB = 0.775V<sub>rms</sub>)

### Video

Signal / noise ratio ..... approx. 43dB (unweighted)  
 Video resolution ..... approx. 3MHz

Input via cinch socket ..... 0.5...2V<sub>pp</sub>, 75 $\Omega$   
 Output via cinch socket ..... 1V<sub>pp</sub>, 75 $\Omega$

**Mains voltage** ..... 110V~...240V~

**Mains frequency** ..... 50 / 60Hz

**Power consumption** ..... approx. 18W

**Ambient temperature** ..... +5°C ... +40°C

**Operating position** ..... horizontal

## Mechanism Adjustment

### 2.1 BEFORE STARTING REPAIR AND ADJUSTMENT

#### 2.1.1 Precautions

- (1) Unplug the power cable of the main unit before using your soldering iron.
- (2) Take care not to cause any damage to the conductor wires when plugging and unplugging the connectors.
- (3) Do not randomly handle the parts without identifying where the trouble is.
- (4) Exercise enough care not to hurt yourself, especially your finger nails, during the repair work.
- (5) When installing the front panel assembly, be sure to hook the lug on the back side of cassette door to the door opener of the cassette holder. If this operation is neglected it will not be possible to remove the cassette when ejecting because the housing door cannot be opened.

#### 2.1.2 Checking for Proper Mechanical Operations

Enter the mechanism service mode when you want to operate the mechanism when no cassette is loaded. (See 1.5 MECHANISM SERVICE MODE)

#### 2.1.3 Manually Removing the Cassette Tape

##### 1. In case of electrical failures

If you cannot remove the cassette tape which is loaded because of any electrical failure, manually remove it by taking the following steps.

- (1) Unplug the power cable and remove the top cover, bracket and, front panel assembly.  
(See 1.3 DISASSEMBLY/ASSEMBLY METHOD)
- (2) Unload the cassette by manually turning the unloading motor of the main deck assembly toward the front. In doing so, hold the tape by the hand to keep the slack away from any grease. (See Fig.2-1-1)
- (3) Bring the pole base assembly (on the supply or take-up side) to a pause when it reaches the position where it is hidden behind the cassette tape.
- (4) Move the top plate toward the drum while holding down the lug **(A)** of the bracket retaining the top plate. Likewise hold part **(B)** down and remove the top plate. The spring plate **(C)** is then brought under the cassette lid. Then remove the top plate by pressing the whole cassette tape down. (Note 1) (See Fig.2-1-2).
- (5) Remove the cassette tape by holding both the slackened tape and the cassette lid.
- (6) Take up the slack of the tape into the cassette. This completes removal of the cassette tape.

**Note:** *The spring plate of the top plate is sharp-edged. Take care not to hurt yourself.*

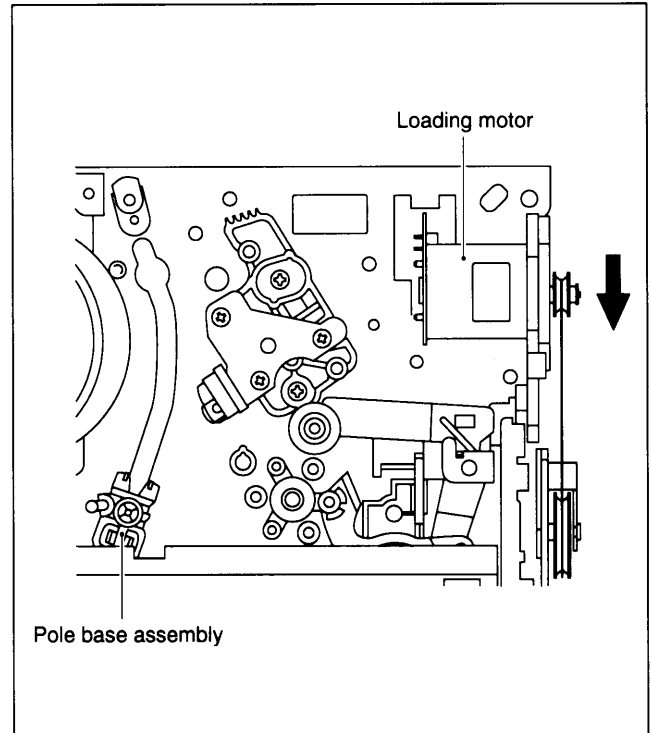

Fig. 2-1-1

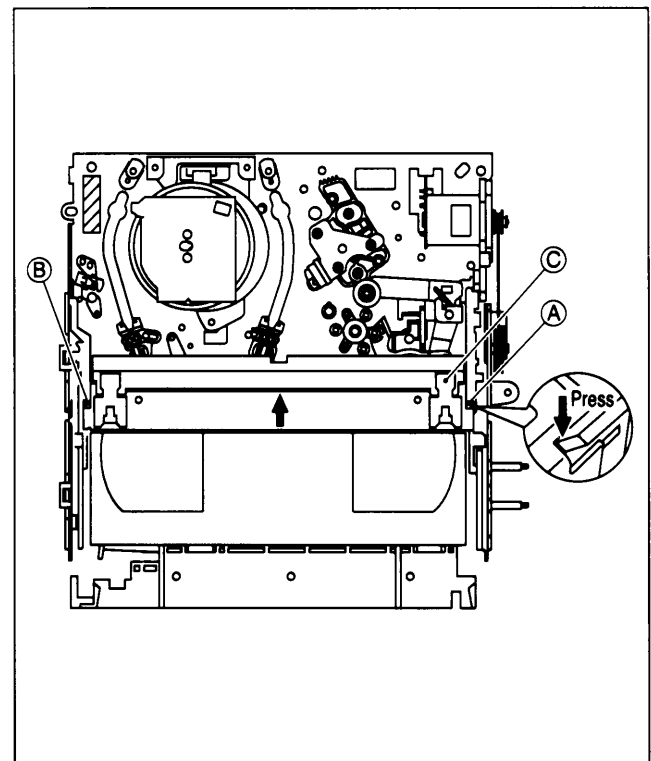

Fig. 2-1-2

## 2. In case of mechanical failure

If you cannot remove the cassette tape which is loaded because of any mechanical failure, manually remove it by taking the following steps.

- (1) Unplug the power cable and remove the top cover, bracket, front panel assembly, stay and Drum shield (See 1.3 DISASSEMBLY/ASSEMBLY METHOD).
- (2) While keeping the tension arm of the main deck assembly free from tension, pull the tape on the pole base assembly out of the guide roller (on the supply or take-up side) (See Fig.2-1-3).
- (3) Remove the top plate as done in Step (4) of "1. In case of electrical failures" and remove the guide pole cap at the same time. (See Fig.2-1-4).
- (4) While lifting the cassette tape lid, hold the cassette tape case and pinch roller by the fingers and move them toward the loading motor to relieve pressure on the tape. Then remove the tape while taking the cassette case out of the cassette holder. (See Fig.2-1-4).
- (5) Replace the guide pole cap and take up the slack of the tape into the cassette.

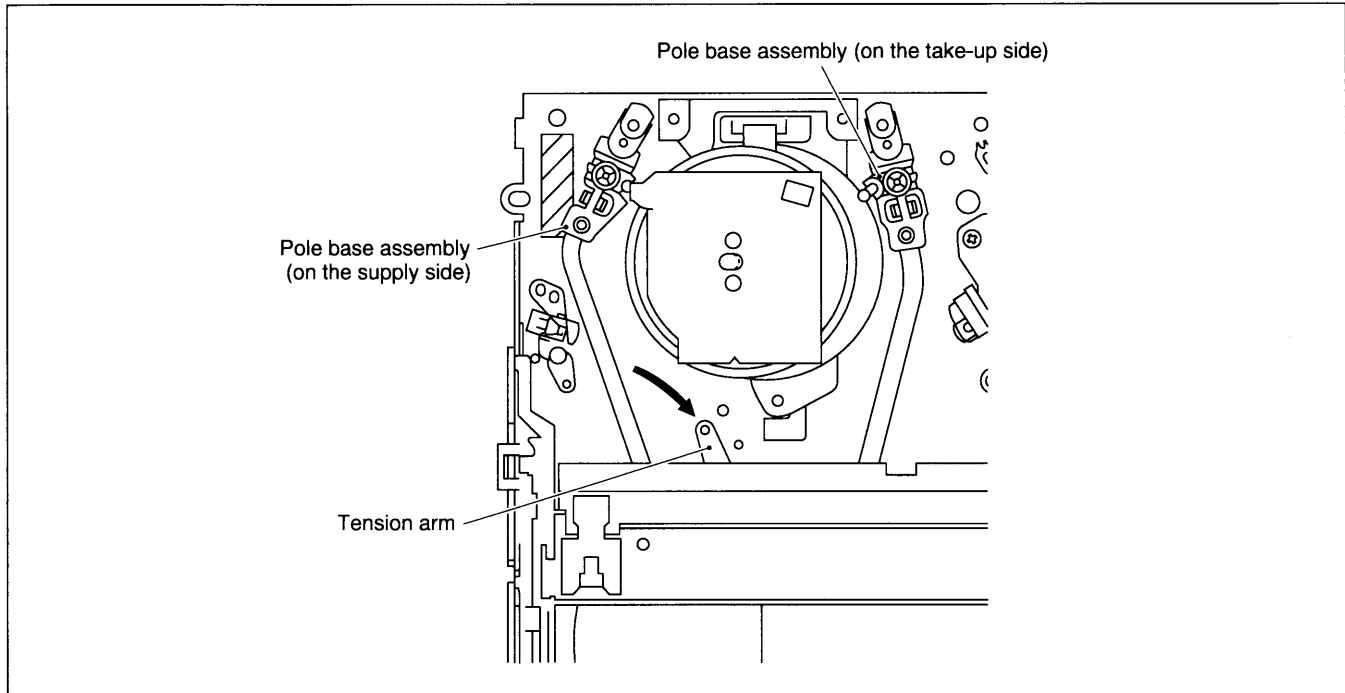

Fig. 2-1-3

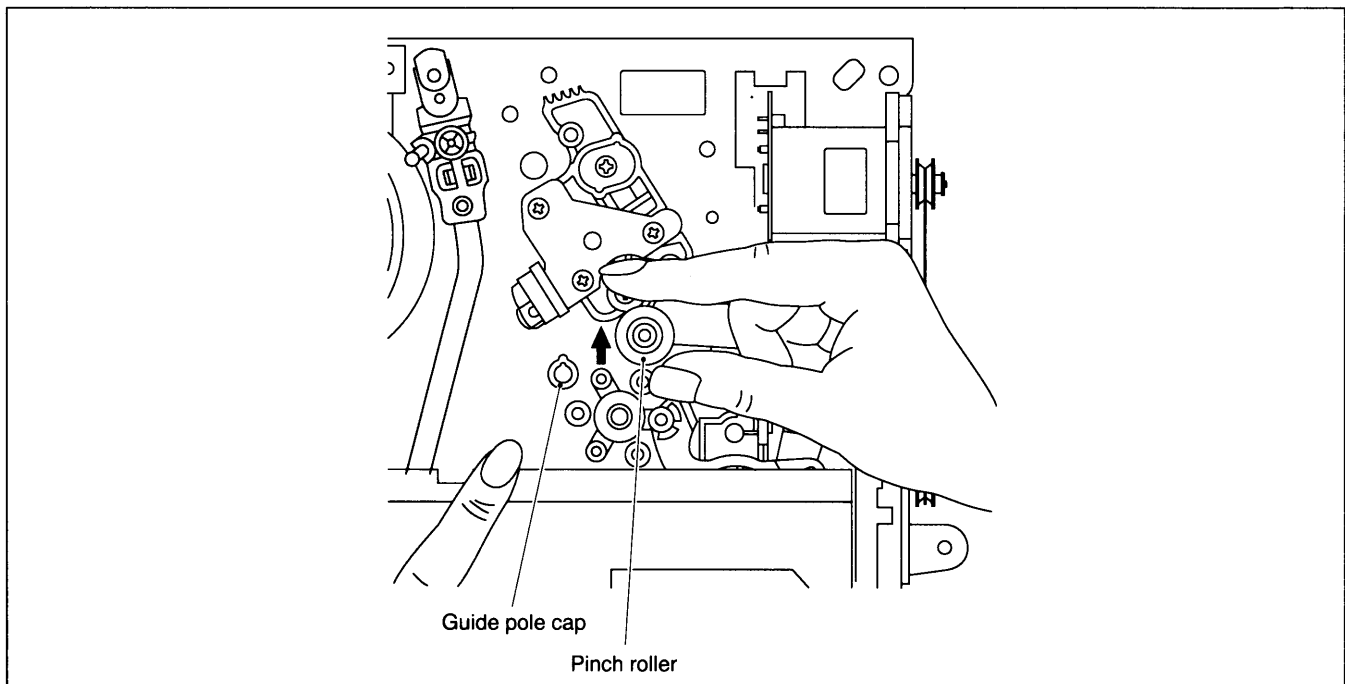
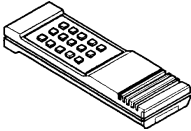
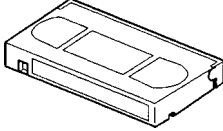
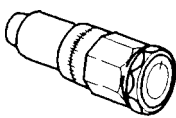
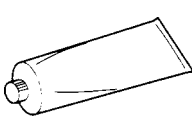
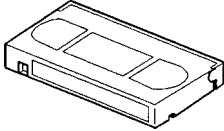

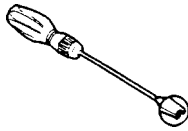

Fig. 2-1-4

2.1.4 Test equipment

Presetting unit 75981 311 2600 	Alignment tape 75981 311 2700 	Torque gauge 75981 311 3200 	Grease 75988 034 7400 
Back tension cassette gauge 75981 311 3300 	A/C head positioning tool 75981 311 3400 	Roller driver 75981 311 3500 	

2.1.5 Maintenance and Inspection

1. Location of major mechanical parts

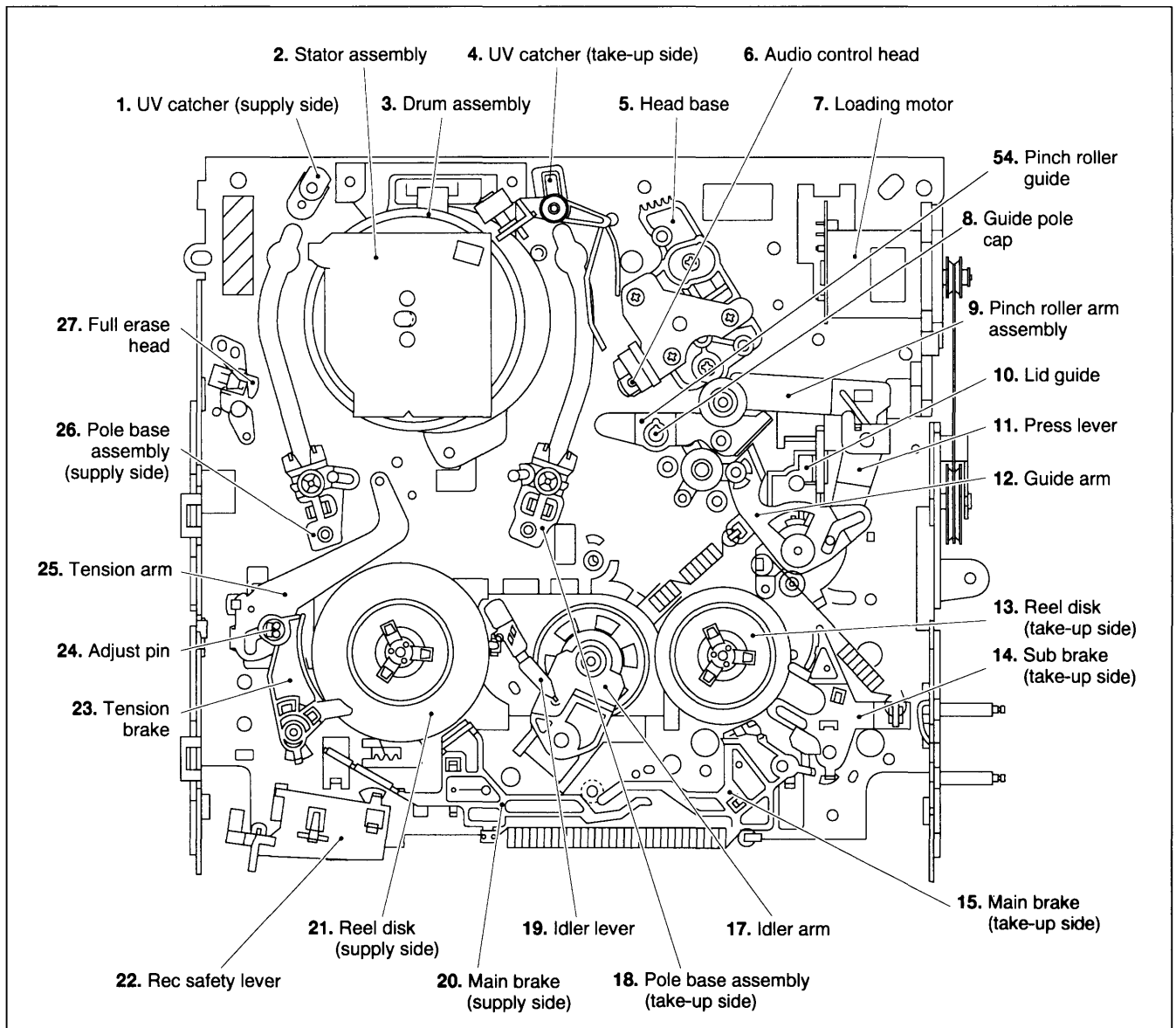

Fig. 2-1-5 Main deck top side

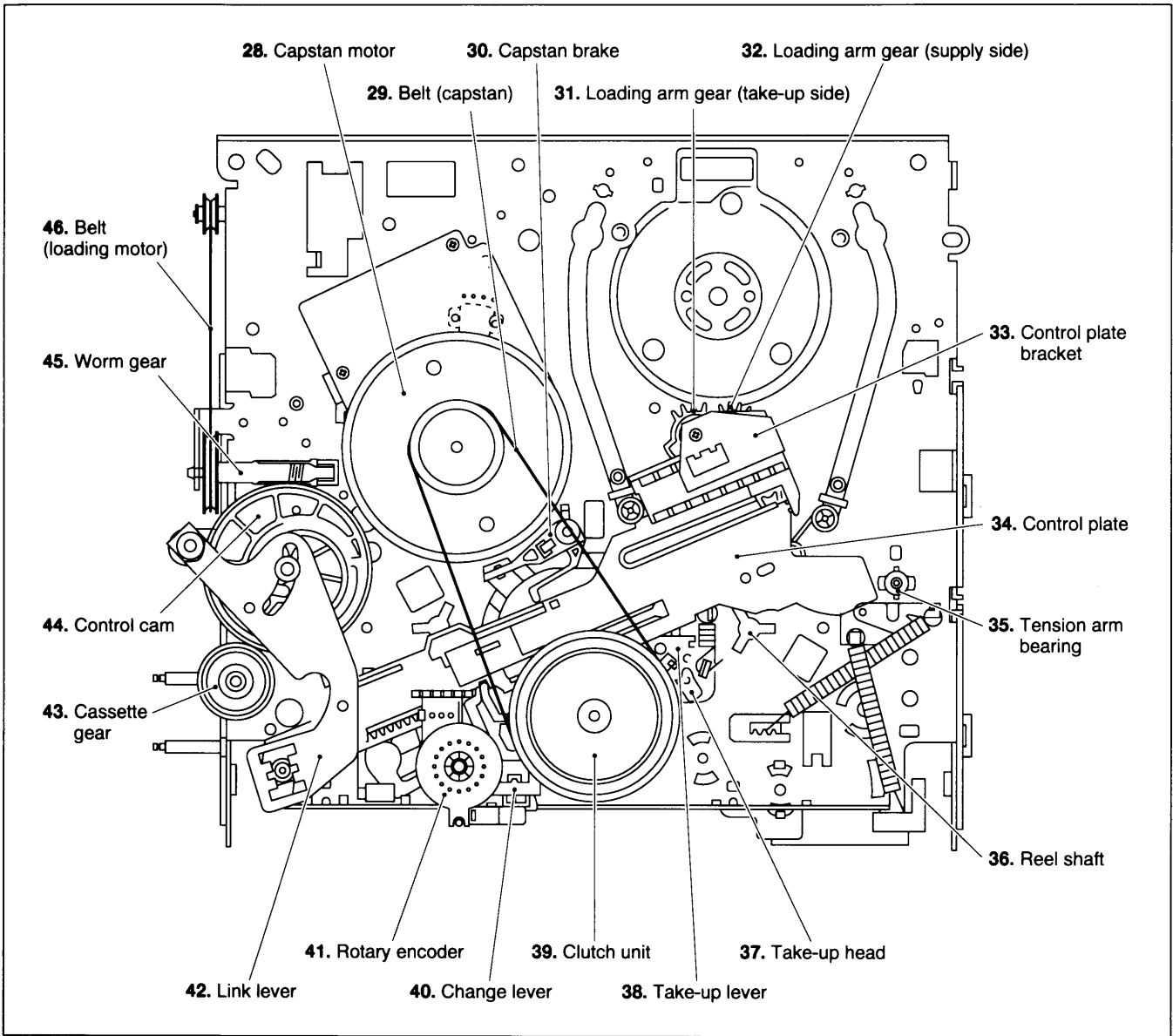

Fig. 2-1-6 Main deck bottom side

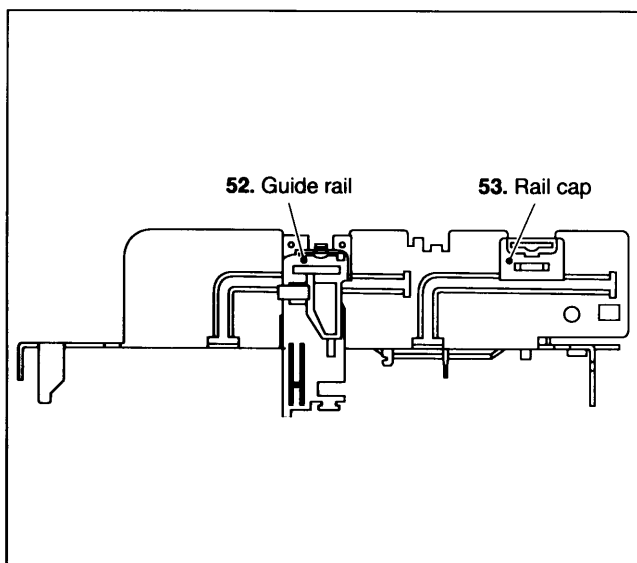

Fig. 2-1-7 Main deck left side

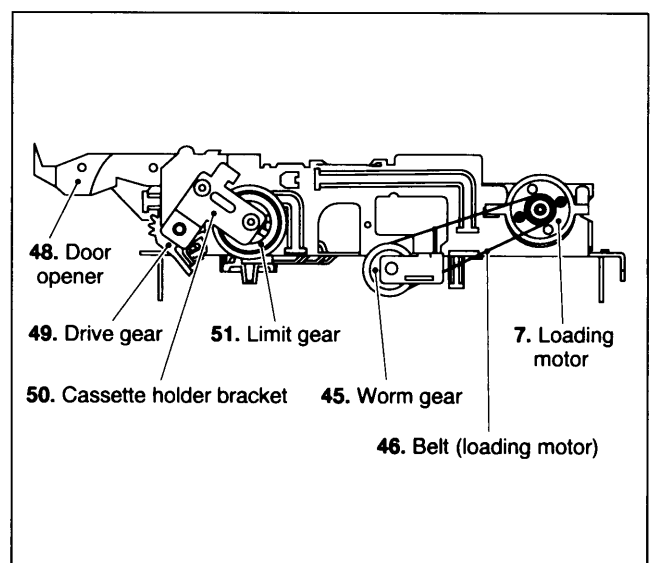

Fig. 2-1-8 Main deck right side

**Note:** Numerals at the start of the parts names are identical with those of the location diagrams of the major mechanical parts, 1 - 18 of which denote the order of removal. Of the alphabets T and B next to the parts names, T denotes removal from the main deck top side, B from the bottom side and T/B from both sides.

Removable parts names Replacement parts names		1 4 12 53 46 9 52 11 50 - - - 49 32 - - 38 25 23 31 21 42 41 29 39 40 33 34 14 19 54																											
		UV catcher	Guide arm assembly	Rail cap	Belt (loading motor)	Pinch roller arm assembly	Guide rail	Press lever assembly	Cassette Holder bracket	Opener guide	Relay gear	Cassette holder assembly	Drive gear	Loading arm gear (supply side)	Drive arm assembly	Tension spring	Take-up lever	Tension arm assembly	Tension brake assembly	Loading arm gear (take-up side)	Reel base (supply side)	Link lever	Rotary encoder	Belt (capstan motor)	Clutch unit	Change lever	Control plate bracket	Control plate	Sub brake
17	Idler arm	T		1		2	3	4	5	6	7	8						9	10	11	12	13	14	15	16	17	18		
15	Main brake (take-up side)	T/B		1		2	3	4	5	6	7	8									9	10	11	12	13	14	15	16	
13	Reel disk (take-up side)	T		1		2	3	4	5	6	7	8									9	10	11	12	13	14	15	16	
19	Idler lever	T/B		1		2	3	4	5	6	7	8						9	10	11	12	13	14	15	16	17			
-	Rotary encoder guide	T/B		1		2	3	4	5	6	7	8									9	10	11	12	13	14	15	16	
14	Sub brake (take-up side)	T/B		1		2	3	4	5	6	7	8									9	10	11	12	13	14	15		
-	Loading arm gear shaft	B										8							9		1	2	3	4	5	6	7		
35	Tension arm bearing	T		1		2	3	4	5	6					8		9	7											
-	Control plate guide	T/B														8						1	2	3	4	5	6	7	
37	Take-up head	B														8						1	2	3	4	5	6	7	
31	Loading arm gear (take-up side)	B											8								1	2	3	4	5	6	7		
25	Tension arm assembly	T/B		1		2	3	4	5	6					8			7											
20	Main brake (supply side)	T/B		1		2	3	4	5	6	7	8																	
38	Take-up lever	T/B																				1	2	3	4	5	6	7	
32	Loading arm gear (supply side)	B																			1	2	3	4	5	6	7		
21	Reel disk (supply side)	T		1		2	3	4	5	6	7																		
-	Drive arm assembly	T		1		2	3	4	5	6	7																		
30	Capstan brake	T/B																				1	2	3	4	5	6	7	
34	Control plate	B																				1	2	3	4	5	6		
23	Tension brake assembly	T/B		1		2	3	4	5	6																			
-	Cassette holder assembly	T		1		2	3	4	5																				
-	Direct gear	B																				1	2	3	4				
10	Lid guide	T		1		2	3																						
40	Change lever	B																				1	2	3					
49	Drive gear	T						1	2	3																			
11	Press lever assembly	T		1		2																							
-	Relay gear	T						1	2																				
51	Limit gear assembly	T						1	2																				
26	Pole base assembly (supply side)	T/B	1																										
18	Pole base assembly (take-up side)	T/B	1																										
-	Tension spring (Main brake)	T																											
22	Rec safety lever	T/B																											
28	Capstan motor	T/B																					1						2
45	Worm gear	B			1																								
44	Control cam	B																				1							
43	Cassette gear	B																				1							
39	Clutch unit	B																					1						
9	Pinch roller arm assembly	T		1																									
-	Opener guide	T						1																					
8	Guide pole cap	T																											
1,4	UV catcher	T																											
42	Link lever	B																											
41	Rotary encoder	B																					1						
12	Guide arm assembly	T																											
50	Cassette holder bracket	T																											
52	Guide rail	T																											
53	Rail cap	T																											
7	Loading motor assembly	T																											
5	A/C head assembly	T																											
54	Pinch roller guide	T																											

## 2. Cleaning

Regular cleaning of the transport system parts is desirable but practically impossible. So make it a rule to carry out cleaning of the tape transport system whenever the machine is serviced.

When the video head, tape guide and/or brush get soiled, the playback picture may appear inferior or at worst disappear, resulting in possible tape damage.

- (1) When cleaning the upper drum (especially the video head), soak a piece of closely woven cloth or Kimu-wipe with alcohol and while holding the cloth onto the upper drum by the fingers, turn the upper drum counterclockwise.

**Note:** *Absolutely avoid sweeping the upper drum vertically as this will cause damage to the video head.*

- (2) To clean the parts of the tape transport system other than the upper drum, use a piece of closely woven cloth or a cotton swab soaked with alcohol.
- (3) After cleaning, make sure that the cleaned parts are completely dry before using the video tape.

## 3. Lubrication

With no need for periodical lubrication, you have only to lubricate new parts after replacement. If any oil or grease on contact parts is soiled, wipe it off and newly lubricate the parts.

- (1) See the mechanism assembly and disassembly diagrams (M4) for the lubricating or greasing spots. See Table 2-1-2 for the types of oil or grease to be used.

Category	Part No.	Symbols on the dis-assembly diagrams
Oil	75981 311 3000	AA
Grease	75988 034 7400	BB

Table 2-1-2 Grease and oil used for the unit

## 4. Suggested servicing schedule for main components

The following table indicates the suggested period for such service measures as cleaning, lubrication and replacement. In practice, the indicated periods will vary widely according to environmental and usage conditions. However, the indicated components should be inspected when a set is brought for service and the maintenance work performed if necessary. Also note that rubber parts may deform in time, even if the set is not used.

System	Parts Name	Operation Hours	
		~1000H	~2000H
Tape transport	Upper drum assembly	★○	○
	A/C head	★○	★○
	Lower drum assembly	★	★○
	Pinch roller arm assembly	★	★
	Full erase head	★	★
	Tension arm assembly	★	★
	Capstan motor (Shaft)	★	★
	Guide arm assembly	★	★
Drive	Capstan motor		○
	Capstan brake		○
	Main brake		○
	Belt (Capstan)	○	○
	Belt (Loading motor)		○
	Loading motor		○
	Clutch unit		○
	Worm gear assembly		○
	Control plate		○
Other	Brush assembly	★○	★○
	Tension brake	○	○
	Rotary encoder		○

★: Cleaning

○: Inspection or Replacement if necessary

Table 2-1-3



**2.2 REPLACEMENT OF MAJOR PARTS**

**2.2.1 Before Starting Disassembling**

This unit is provided with a mechanism assembly mode. It is therefore necessary to enter this mode for assembling and disassembling procedures.

This mode is usually not in use, manually set it when it is required.

**2.2.2 How to Set the Mechanism Assembling Mode**

Remove the main deck assembly and place it bottom side up. (See SECTION 1 DISASSEMBLY). Turn the worm gear toward the front so that the register hole of the control cam is brought into alignment with the hole at the main deck assembly chassis. This position renders the mechanism assembling mode operational. Make sure that the control plate is located in alignment with the mark E. (See Fig.2-2-1)

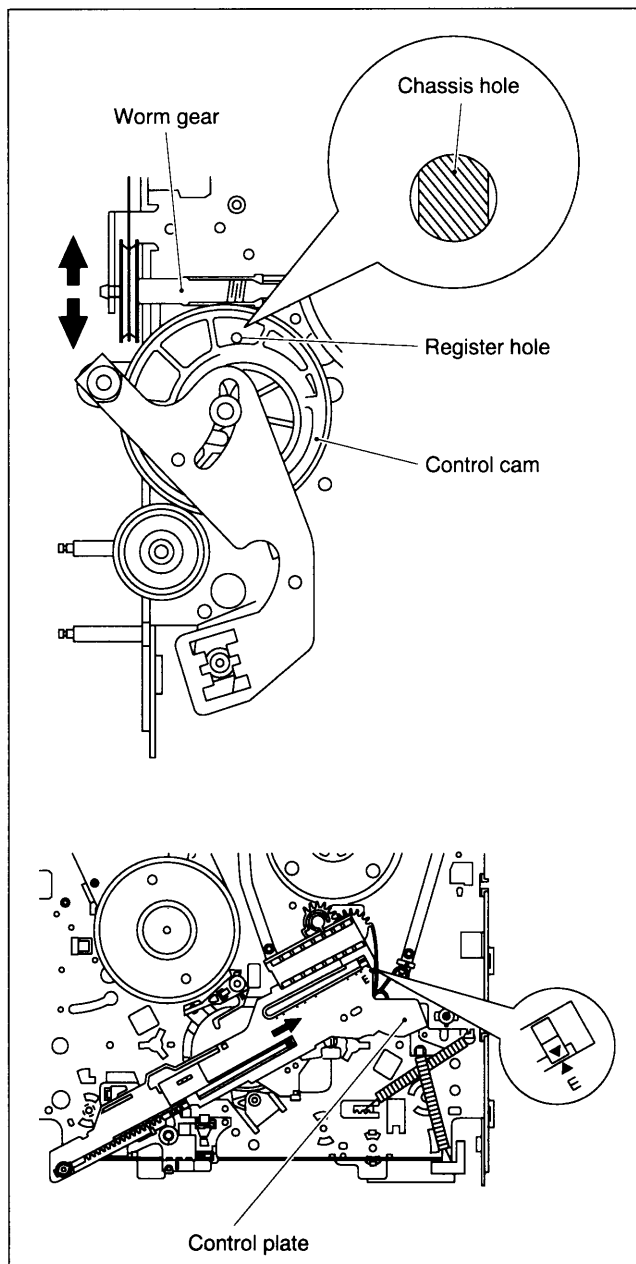

Fig. 2-2-1

**2.2.3 Cassette Holder Assembly**

**1. How to remove**

- (1) Remove the guide rail and rail cap. (See Fig.2-2-2).
- (2 lugs on the guide rail and one lug on the rail cap)

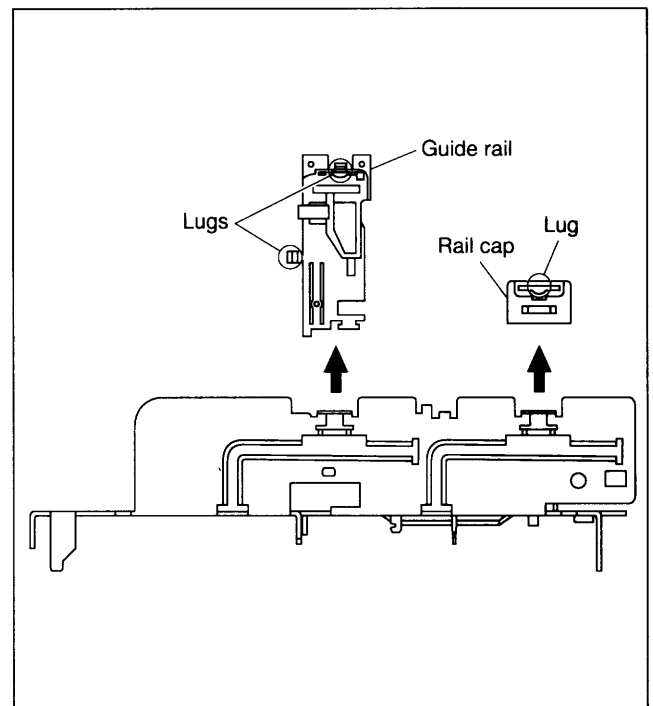

Fig. 2-2-2

- (2) Remove the two slit washers and remove the cassette holder bracket. (See Fig.2-2-3)
- (3) Remove the opener guide, relay gear and limit gear. (See Fig.2-2-3)

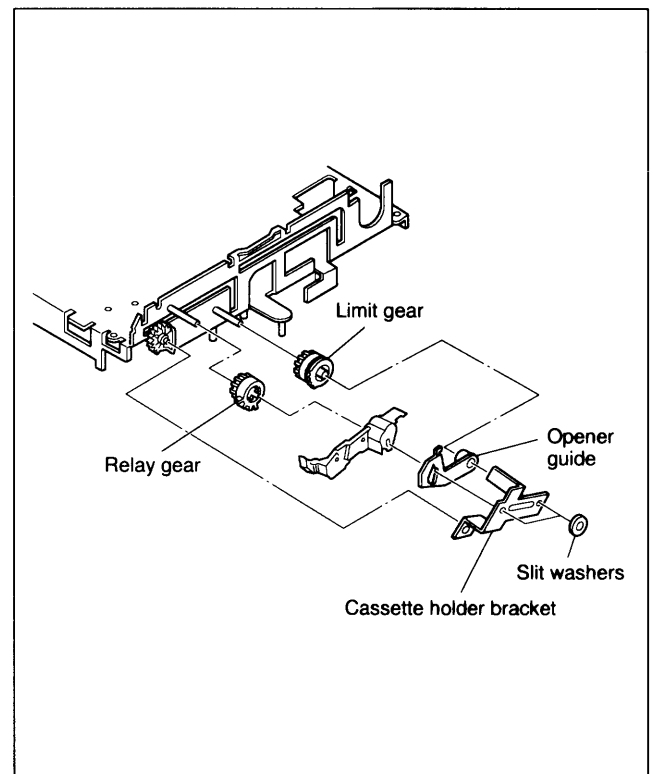

Fig. 2-2-3

(4) While swinging the lock levers (R) and (L) of the cassette holder assembly toward the front, slide the cassette holder assembly until its legs come to where the guide rail and the rail cap have been removed (so that the drive arm is upright). (See Fig.2-2-4)

(5) While holding the left side of the cassette holder, lift the cassette holder assembly so that the three legs on the left side are all released. Then pull the legs (A) and (B) on the right side out of the rail and also pull up the leg (C). (See Fig.2-2-5, Fig.2-2-6)

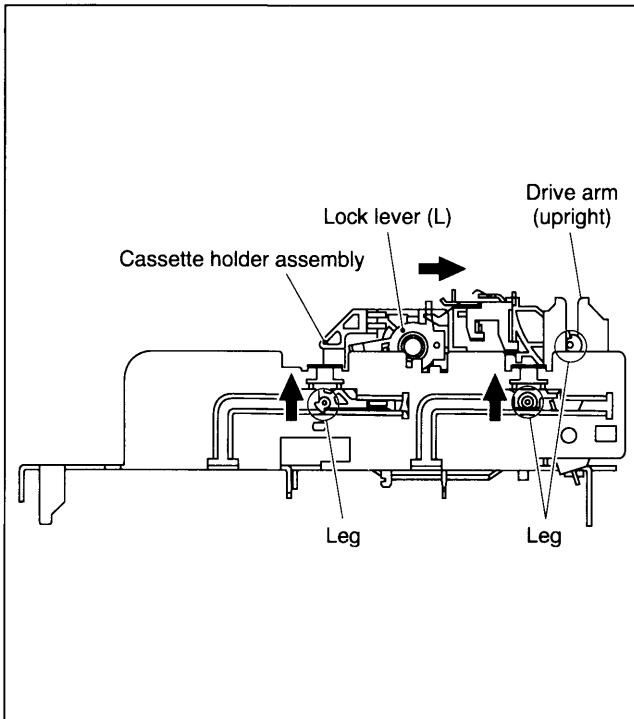

Fig. 2-2-4

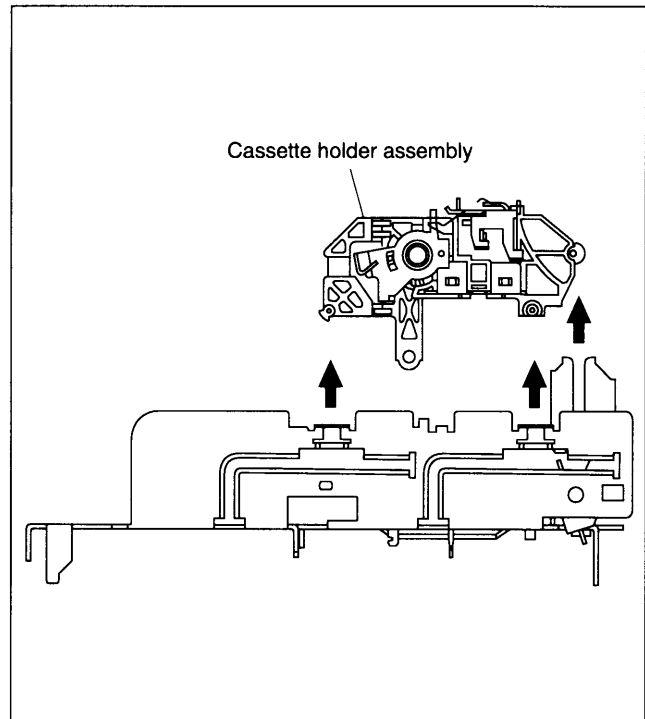

Fig. 2-2-5

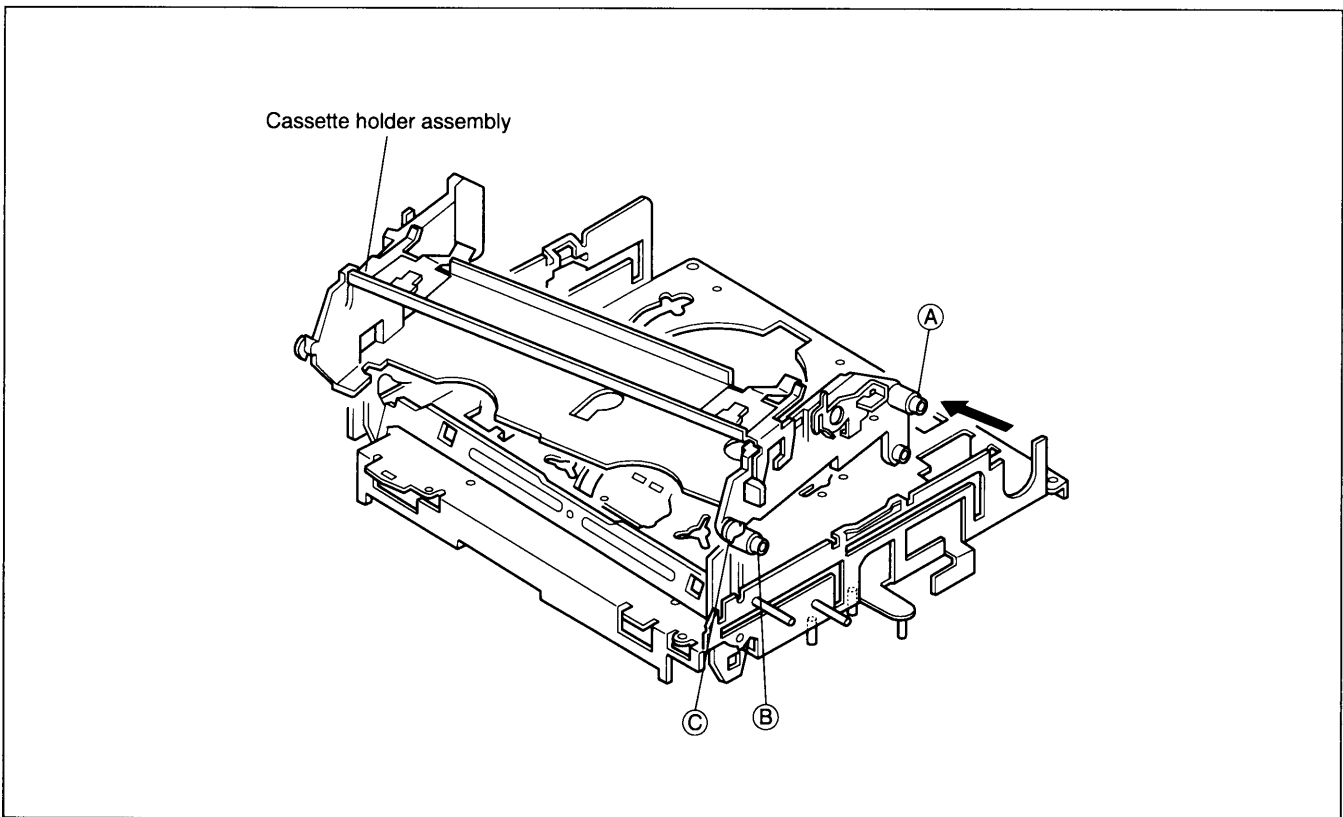

Fig. 2-2-6

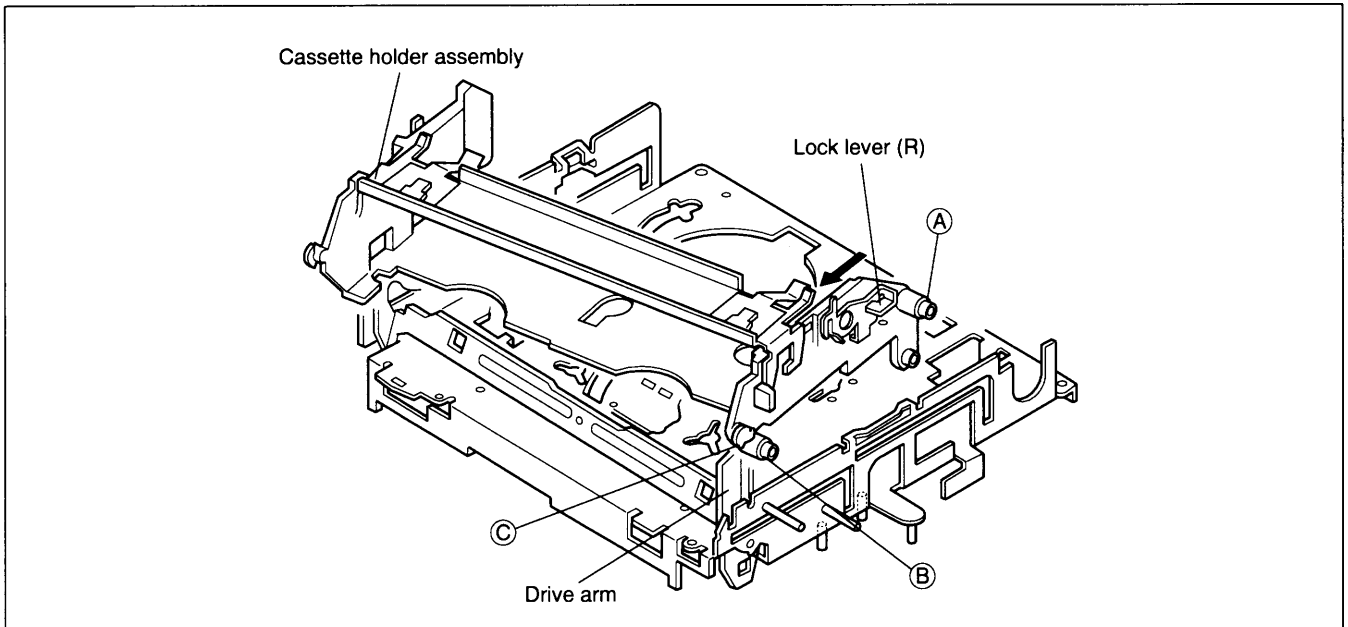

Fig. 2-2-7

**2. How to install**

- (1) Hold the drive arm upright and fit the leg (C) on the right side of the cassette holder assembly into the groove. (See Fig.2-2-7)
- (2) While swinging the lock lever (R) of the cassette holder assembly toward front, put the legs (A) and (B) into the rail. (See Fig.2-2-7)
- (3) Drop the three legs on the left side of the cassette holder into the groove at one time. (See Fig.2-2-8)
- (4) Slide the whole cassette holder toward the front to bring it to the eject end position.
- (5) Install the limit gear so that the notch on the outer circumference of the limit gear is brought into alignment with the register hole on the main deck. (See Fig.2-2-9)
- (6) Install the relay gear so that the notch on the outer circumference of the relay gear is brought into alignment with the notch on the main deck. It is important at this stage that the register hole at the limit gear, the register hole at the relay gear and the register hole at the drive gear are all in alignment. (See Fig.2-2-9).
- (7) Install the door stopper, opener guide and cassette holder bracket and fasten the two slit washers.

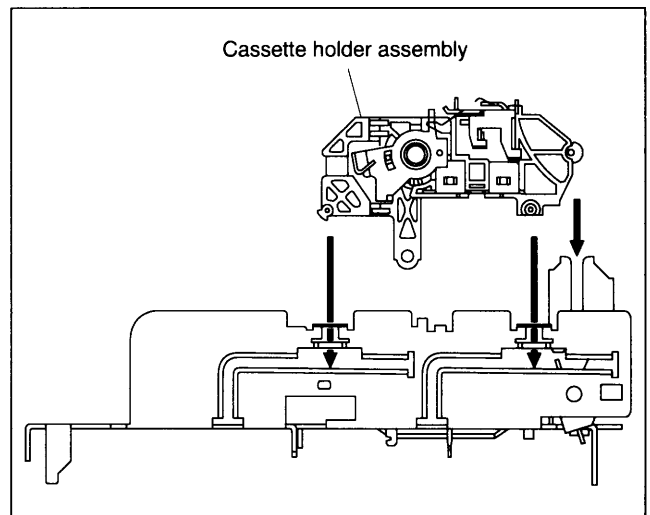

Fig. 2-2-8

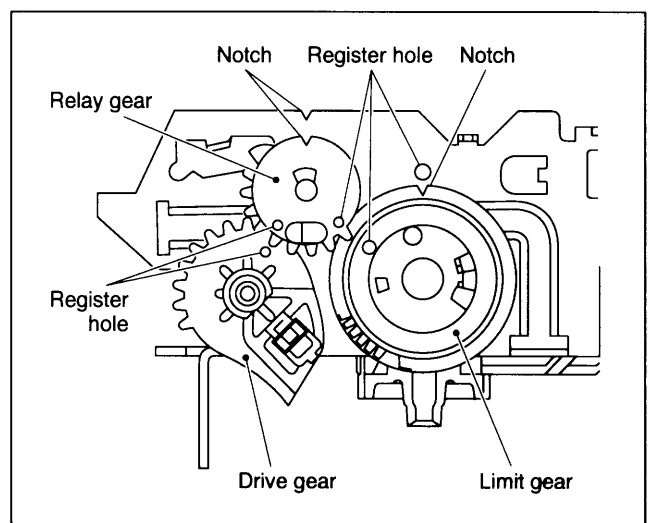

Fig. 2-2-9

### 2.2.4 Pinch Roller Arm Assembly

#### 1. How to remove

- (1) Remove the spring from the hook of the press lever.
- (2) Remove the slit washer and remove the pinch roller seat. (See Fig.2-2-10)
- (3) Remove the pinch roller arm assembly by pulling it up.

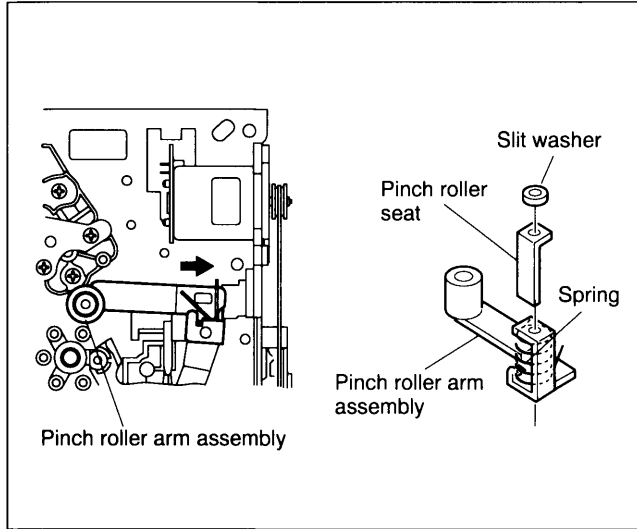

Fig. 2-2-10

### 2.2.5 Guide Arm and Press Lever

#### 1. How to remove

- (1) Remove the spring and expand the lug of the lid guide in the arrow-indicated direction. Then remove the guide arm by pulling it up.
- (2) Remove the press arm by pulling it up. (See Fig.2-2-11)

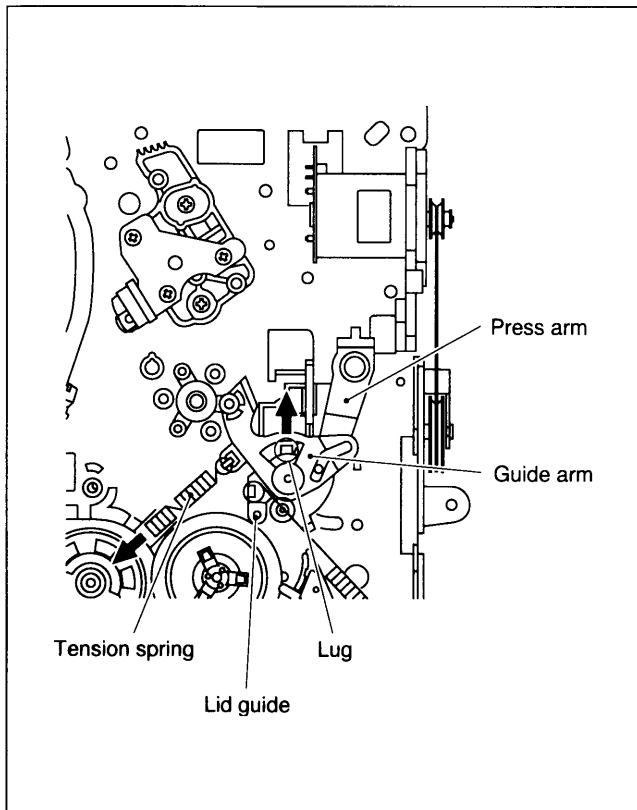

Fig. 2-2-11

### 2.2.6 Audio Control Head

#### 1. How to remove

- (1) Remove two screws (A) and remove the audio control head together with the head base.

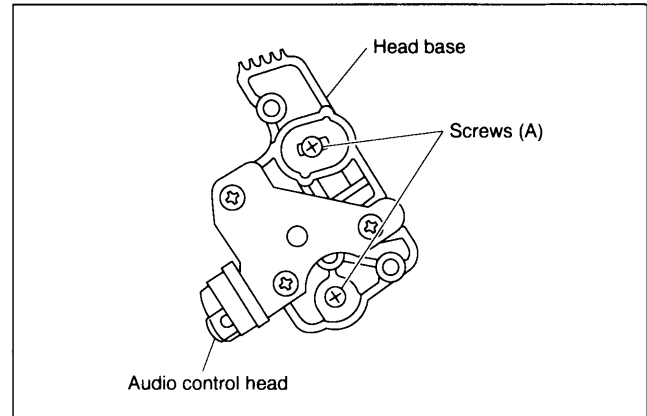

Fig. 2-2-12

- (2) When replacing only the audio control head, remove the three screws (B) while controlling the compression spring.

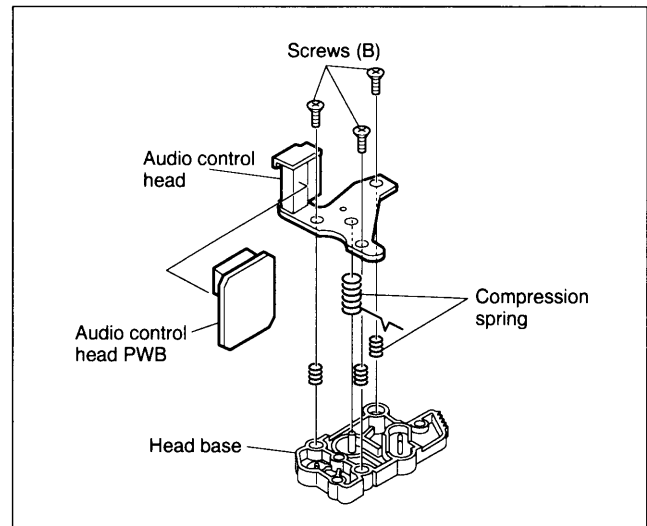

Fig. 2-2-13

#### 2. How to install

- (1) To make the post-installation adjustment easier, set the temporary level as indicated in Fig.2-2-14. Also make sure that the screw center is brought into alignment with the center position of the slot.

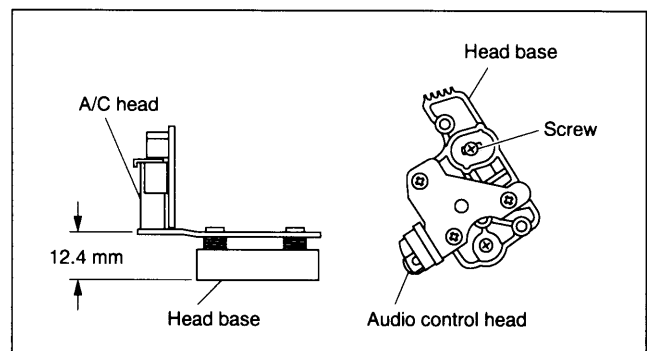

Fig. 2-2-14

### 2.2.7 Loading Motor

#### 1. How to remove

- (1) Remove the belt wound around the worm gear.
- (2) Open the two lugs of the motor guide and remove the loading motor, loading motor PWB and motor guide altogether by pulling them up.
- (3) When replacing the motor base, take care with the orientation of the motor (so that the label faces upward).
- (4) When the motor pulley has been replaced, choose the fitting dimension as indicated in Fig.2-2-15.

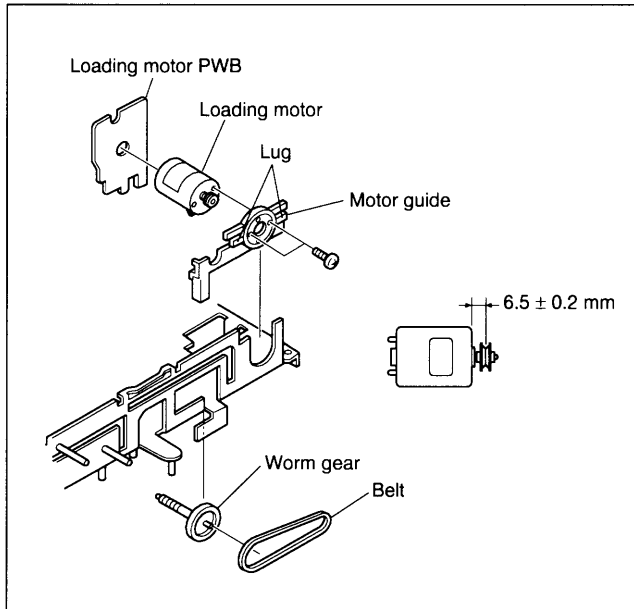

Fig. 2-2-15

### 2.2.8 Capstan Motor

#### 1. How to remove

- (1) Remove the belt (capstan) on the main deck back side.
- (2) Remove three screws (A) and remove the capstan motor.

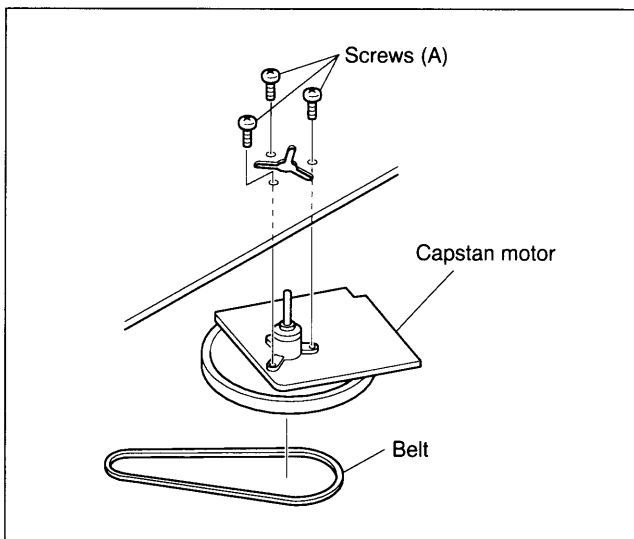

Fig. 2-2-16

#### 2. How to install

Please refer to page 2-25.

### 2.2.9 Pole Base (on the supply or take-up side)

#### 1. How to remove

- (1) Remove the UV catcher on the removal side by loosening one screw (A).
- (2) Remove the pole base on the supply side from the main deck by loosening one screw (B) on the main deck back side and sliding the pole base toward the UV catcher.
- (3) As for the pole base on the take-up side, turn the pulley of the loading motor to lower the cassette holder because the screw (B) is hidden under the control plate (See the "Procedures for Lowering the Cassette holder assembly" on page 1-3 of 1.3 DISASSEMBLY/ASSEMBLY METHOD). Further turn the motor pulley to move the cassette holder until the screw (B) is no longer under the control plate (in the half-loading position). Then remove it as done for the supply side by removing one screw (B).

**NOTE:** After reinstalling the Pole base and the UV catcher, be sure to perform compatibility adjustment.

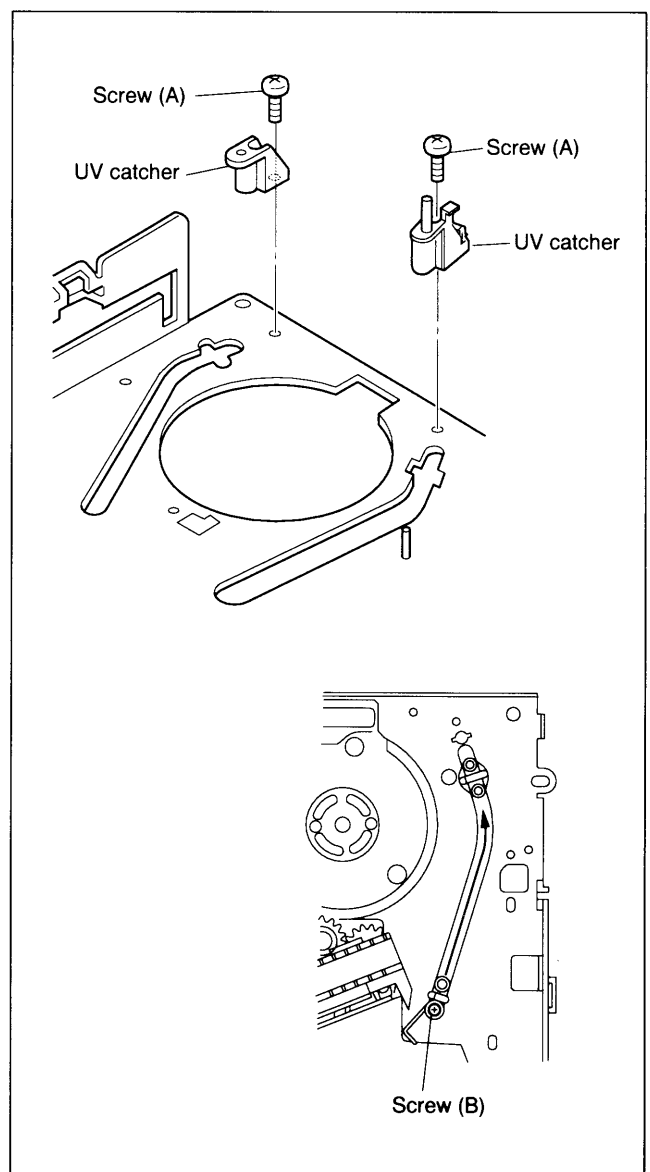

Fig. 2-2-17

**2.2.10 Rotary Encoder**

- (1) Remove one screw (A) and remove the rotary encoder by pulling it up.
- (2) When installing the rotary encoder, bring the register marks into alignment as indicated in Fig.2-2-18.

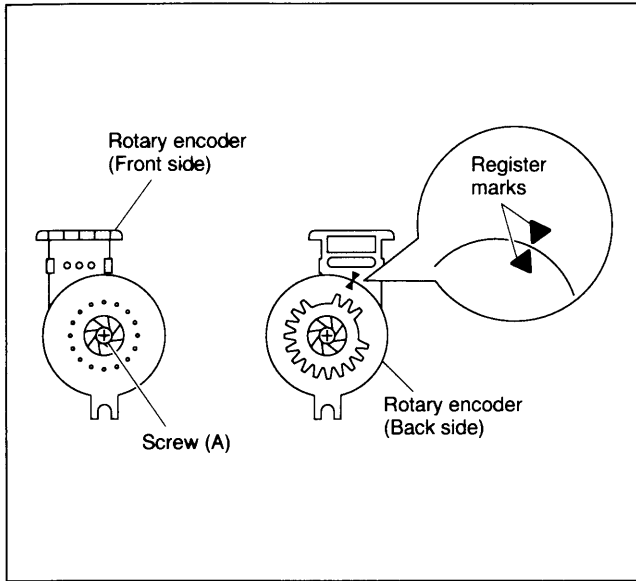

Fig. 2-2-18

**2.2.11 Clutch Unit**

- (1) Remove the belt wound around the capstan motor and the clutch unit.
- (2) Remove the slit washer and remove the clutch unit.

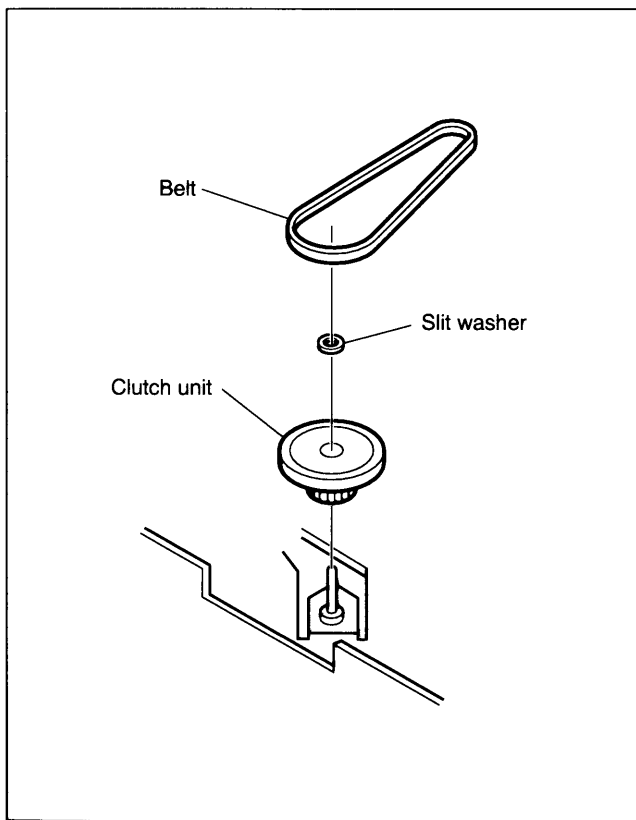

Fig. 2-2-19

**2.2.12 Change Lever and Direct Gear**

- (1) Release two lugs of the rotary encoder guide in the arrow-indicated direction and remove the change lever.
  - (2) Remove the slit washer retaining the direct gear and remove the latter.
- Take care of the two washers and one spring on and under the direct gear. (See Fig.2-2-20)

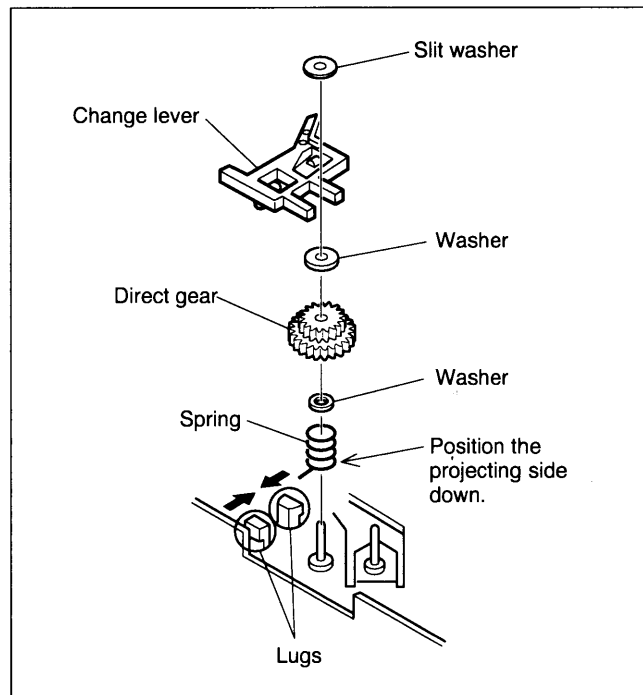

Fig. 2-2-20

**2.2.13 Link Lever**

- (1) Remove the two slit washers.
- (2) Remove the link lever by lifting it from the shaft retained by the slit washers. Then swing the link lever counterclockwise and remove it from the lock member of the control plate.

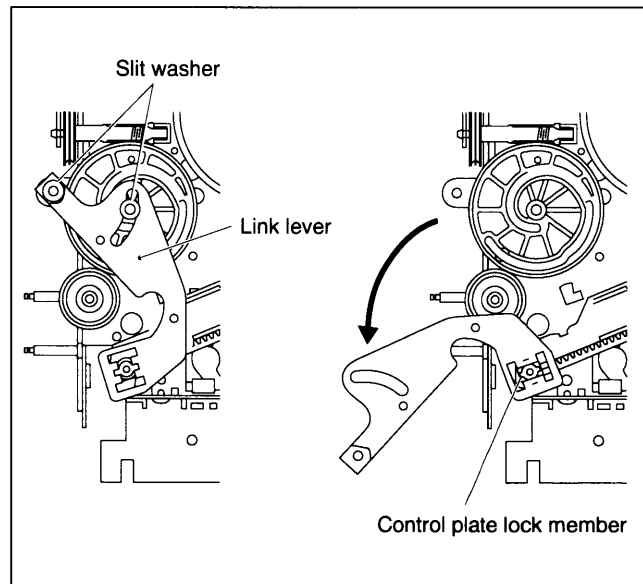

Fig. 2-2-21

**2.2.14 Cassette Gear, Control Cam and Worm Gear**

- (1) Remove the control cam by lifting it.
- (2) Open the two lugs of the cassette gear outward and pull the latter off.
- (3) Remove the belt wound around the worm gear and the loading motor.
- (4) Open the lug of the lid guide outward and remove the worm gear.
- (5) When installing the control cam, make sure that the register hole at the control cam is in alignment with the register hole of the main deck. (See Fig.2-2-22)

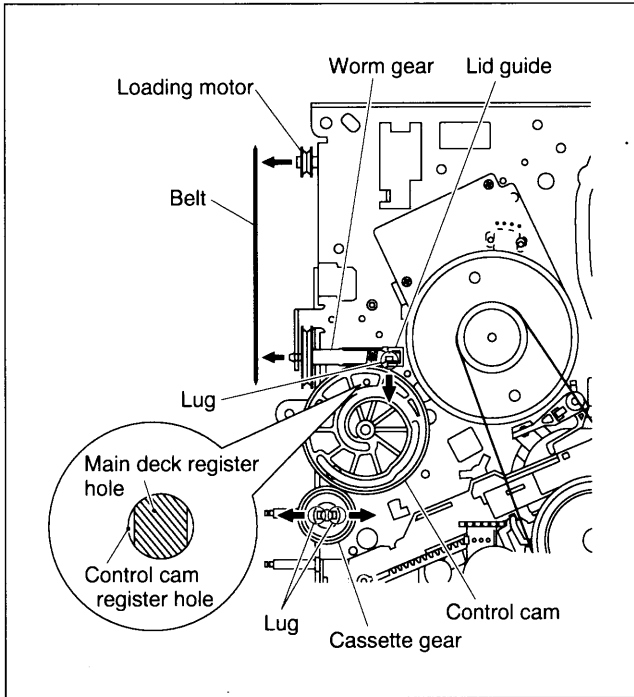

Fig. 2-2-22

**2.2.15 Control Plate**

**1. How to remove**

- (1) Remove one screw (A) retaining the control plate bracket and remove the latter.
- (2) Slide the control plate as indicated by the arrow and remove the control plate. (See Fig.2-2-23)

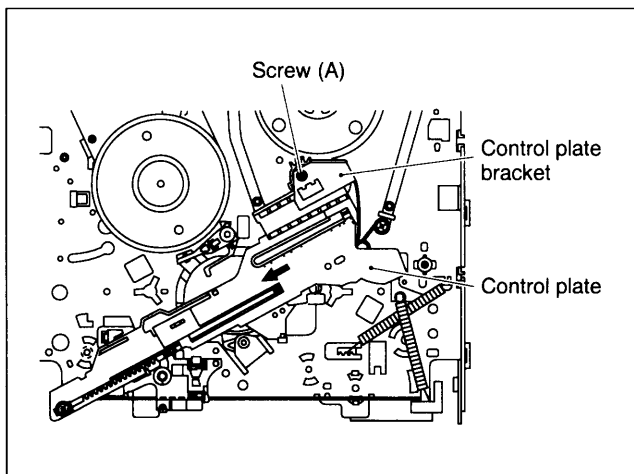

Fig. 2-2-23

**2. How to install**

- (1) Adjust the position of the idler arm pin as indicated in Fig.2-2-24. (to the left of center of the R section)
- (2) Bring the positioning hole of the take-up lever into alignment with the hole at the control plate guide and fix the position by inserting a 1.5 mm hexagonal wrench.
- (3) Press-fit the pole base (on the supply side) as indicated by the arrow and install the control plate so that section A of the loading arm gear shaft fits into hole (A) of the control plate, section B of the control plate guide into hole (B), and the control plate comes under section C of the rotary encoder guide and section D of the loading arm (on the take-up side). Then slide the whole control plate in the arrow-indicated direction. (See Fig.2-2-25).
- (4) Make sure that the mark E of the control plate is in alignment with the mark ▼ of the loading arm gear shaft. (See Fig.2-2-25)
- (5) Pull off the hexagonal wrench for positioning.

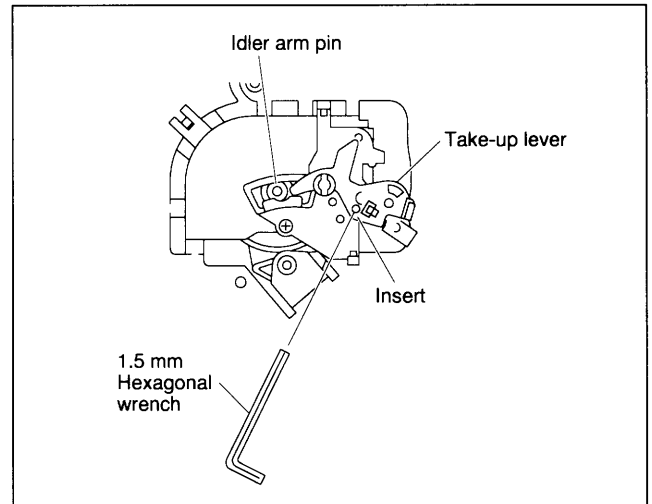

Fig. 2-2-24

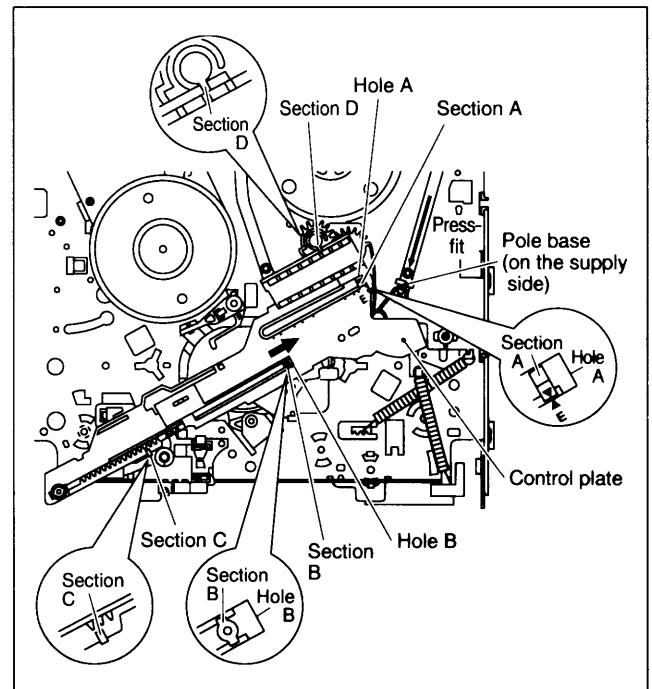

Fig. 2-2-25

## 2.2.16 Loading Arm (on the supply or take-up side) and Loading Arm Gear Shaft

### 1. How to remove

- (1) Remove the loading arm (on the supply side) by loosening screw (A) in Fig.2-2-26.
- (2) Remove screw (B) in Fig.2-2-26 and slide the pole base in the loading direction with the spring held on the pole base (on the take-up side). (See Fig.2-2-26)
- (3) Pull the spring out of the pole base. Turn the loading arm clockwise through about 45 degrees so that the notch of the loading arm is in alignment with the projection of the loading arm gear shaft and lift it. Likewise, turn the loading arm counterclockwise through 180 degrees so that the notch is in alignment with the projection and remove the loading arm (on the take-up side). (See Fig.2-2-27)
- (4) When removing the loading arm gear shaft, be sure of first removing the screw retaining the drum assembly (on the back side of the loading arm gear shaft). Then remove one screw (C) and remove the loading arm gear shaft by sliding it in the arrow-indicated direction.

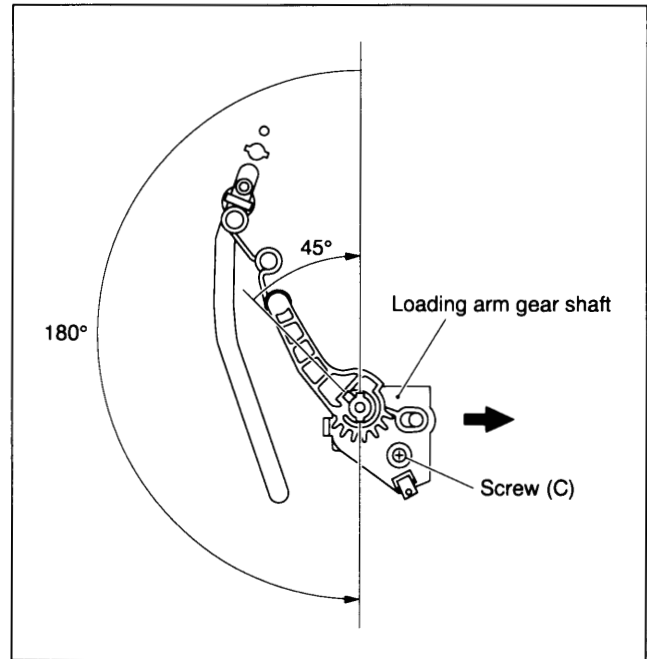

Fig. 2-2-27

### 2. How to install

- (1) Install the loading arm (on the take-up side) as indicated in Fig.2-2-28 and turn it clockwise through 180 degrees so that the loading arm reaches the bottom of the loading arm gear shaft.
- (2) Then turn the loading arm (on the take-up side) counterclockwise through 180 degrees. Hang the spring on the pole base and tighten the screw.
- (3) Install the loading arm (on the supply side) so that the register mark of the loading arm (on the take-up side) is in alignment with the register mark of the loading arm (on the supply side). Then hang the spring on the pole base and tighten the screw. (See Fig.2-2-26).

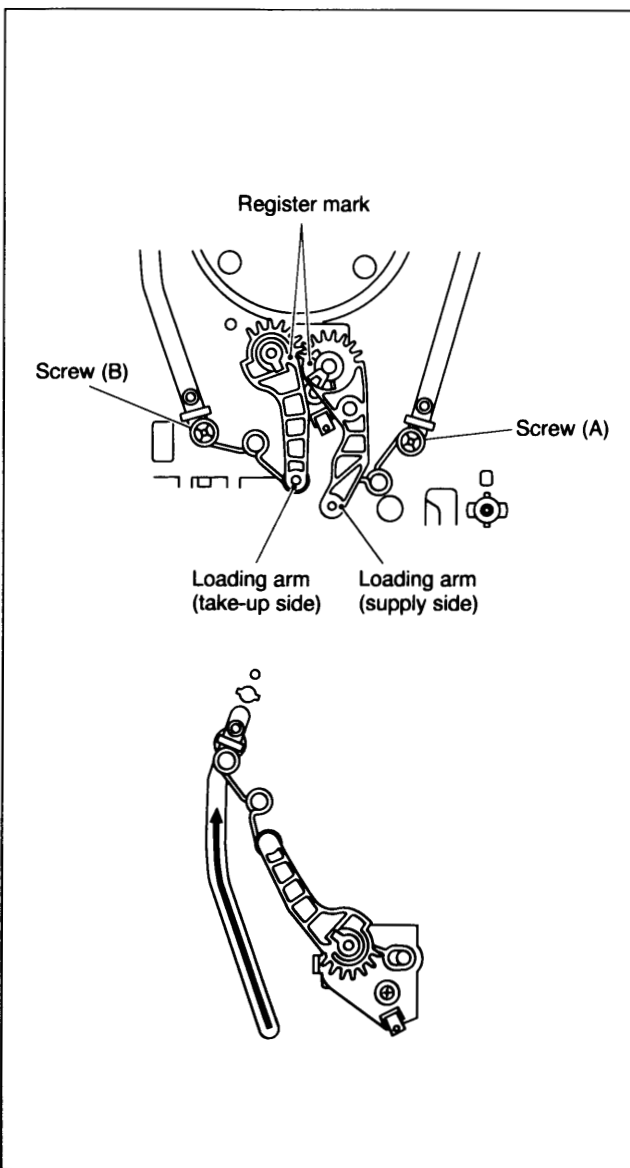

Fig. 2-2-26

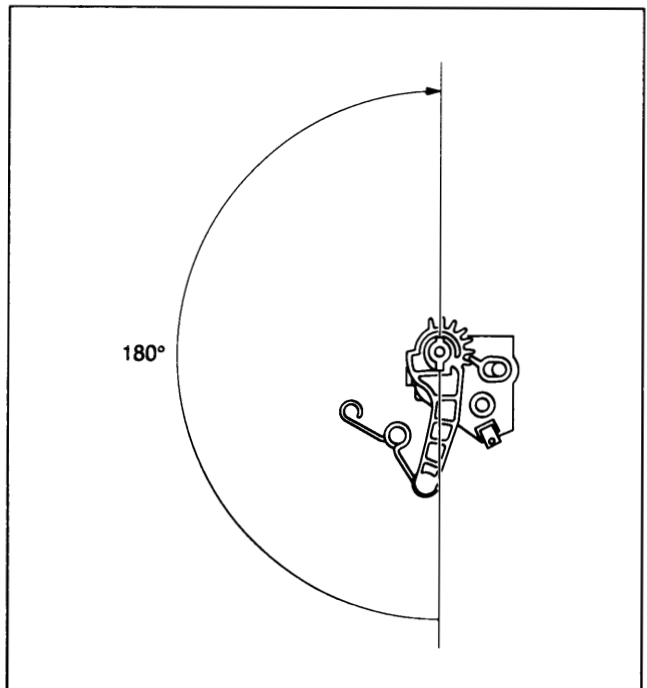

Fig. 2-2-28



**2.2.17 Take-up Lever, Take-up Head and Control Plate Guide**

- (1) Remove the spring of the take-up lever from the main deck.
- (2) Remove one lug of the take-up lever from the main deck and pull out the take-up lever and the take-up head together.
- (3) Remove one screw (A).
- (4) Remove two lugs of the control plate guide from the main deck. Locate the idler arm pin in the center of the R section of the control plate and remove the latter.

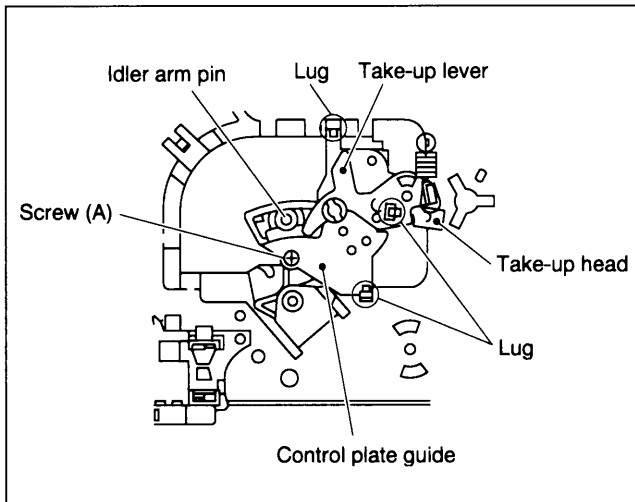

Fig. 2-2-29

**2.2.18 Capstan Brake**

- (1) Move lug (A) of the capstan brake in the arrow-indicated direction so that it comes into alignment with the notch of the main deck. (See Fig. 2-2-30)
- (2) Remove lug (B) of the capstan brake from the main deck and remove the capstan brake.

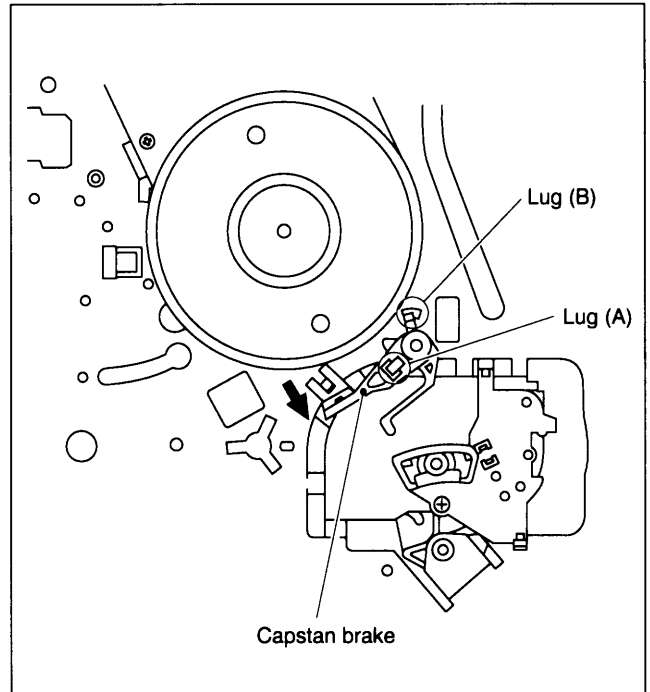

Fig. 2-2-30

**2.2.19 Drive Gear and Drive Arm**

**1. How to remove**

- (1) Remove the cassette holder assembly. (See 2.2.3 How to remove the cassette holder assembly)
- (2) Pull out the drive gear and remove the drive arm.

**2. How to install**

- (1) Insert section (A) of the drive arm into section (B) of the main deck.
- (2) Insert section (1) of drive gear into hole (O) of the drive arm and section (2) into hole (□). (See Fig. 2-2-31)

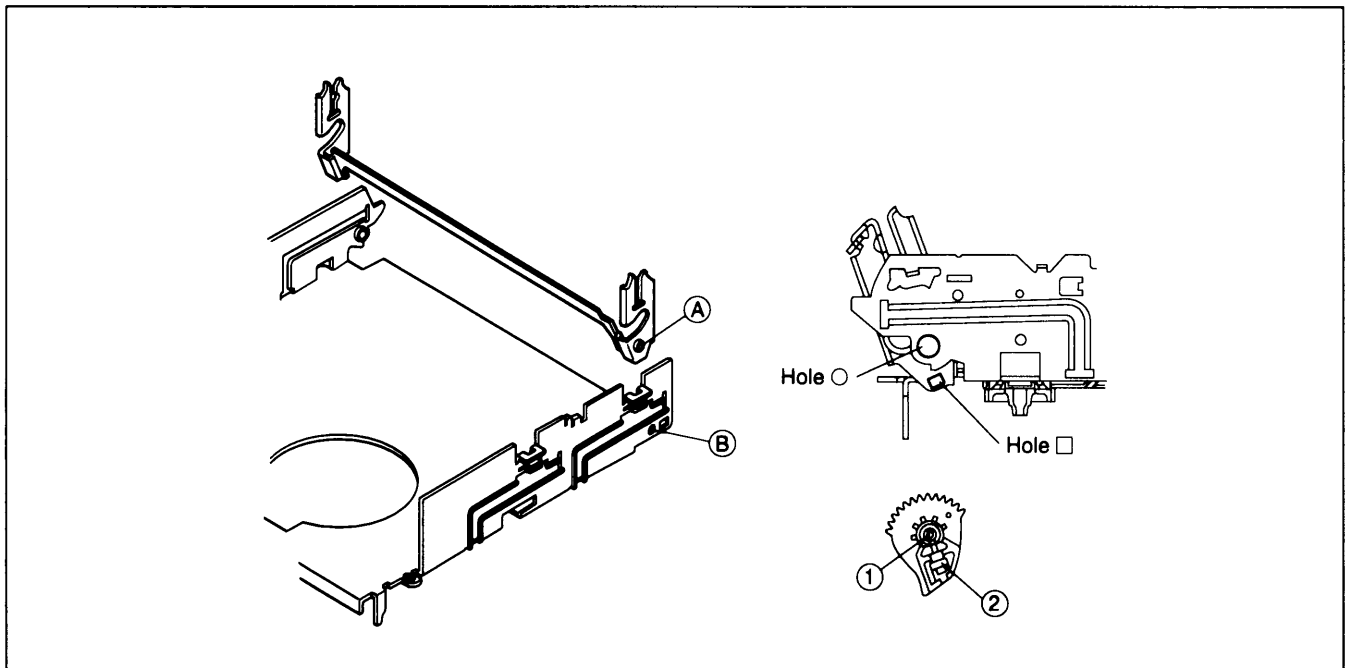

Fig. 2-2-31

### 2.2.20 Sub Brake (on the take-up side)

- (1) Remove the spring attached to the lid guide and sub brake.
- (2) Bring lug (A) of the sub brake into alignment with the notch of the main deck.
- (3) Remove lugs (B) and (C) of the sub brake from the main deck and remove the sub brake.

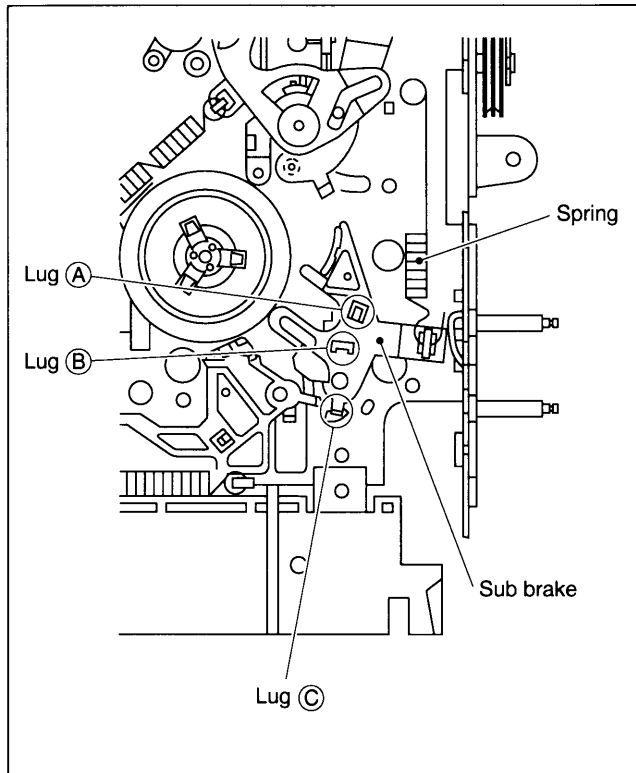

Fig. 2-2-32

### 2.2.21 Main Brake (on the take-up side), Reel Disk (on the take-up side) and Main Brake (on the supply side)

- (1) Move the main brake (on the take-up side) in the arrow-indicated direction and remove the reel disk (on the take-up side).
- (2) Remove the spring attached to the main brake.
- (3) Remove lug (A) of the main brake (on the take-up side) and pull out lug (B) after bringing it into alignment with the main deck notch.
- (4) Remove lugs (C) and (D) of the main brake (on the supply side) from the main deck and pull them off. (See Fig. 2-2-33)

**Note:** If the main brake is difficult to remove, press it and hold the adjustment pin from the back side of the main deck when attempting to remove it. After the adjustment pin has been removed or the main brake or the reel disk on the supply or take-up side have been replaced, it is required to adjust the main brake torque. See page 2-24 for the detailed adjustment procedures.

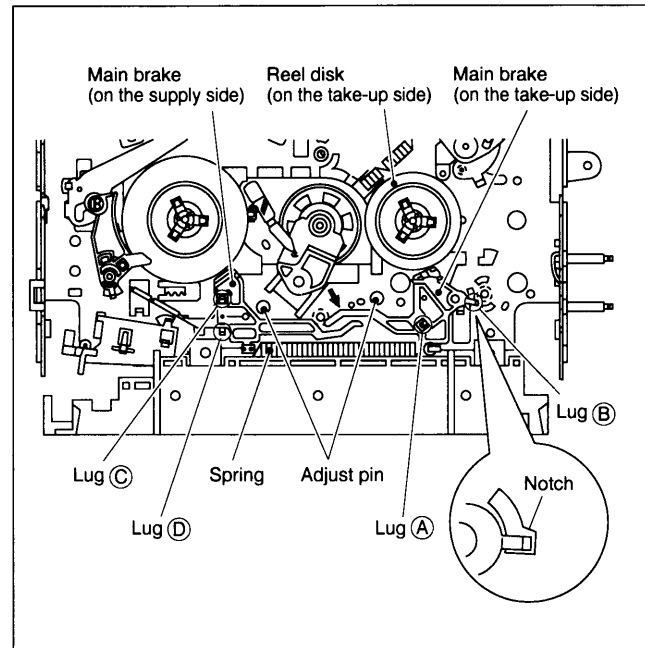

Fig. 2-2-33

### 2.2.22 Tension Brake, Reel Disk (on the supply side) and Tension Arm

- (1) Remove the three lugs of the tension brake from the main deck and pull them off.
- (2) Remove the reel disk (on the supply side) by loosening in the arrow-indicated direction the main brake (on the supply side).
- (3) Remove the tension spring on the main deck back side and remove the lugs of the tension arm bearing to pull up and remove the tension arm. (See Fig. 2-2-34)

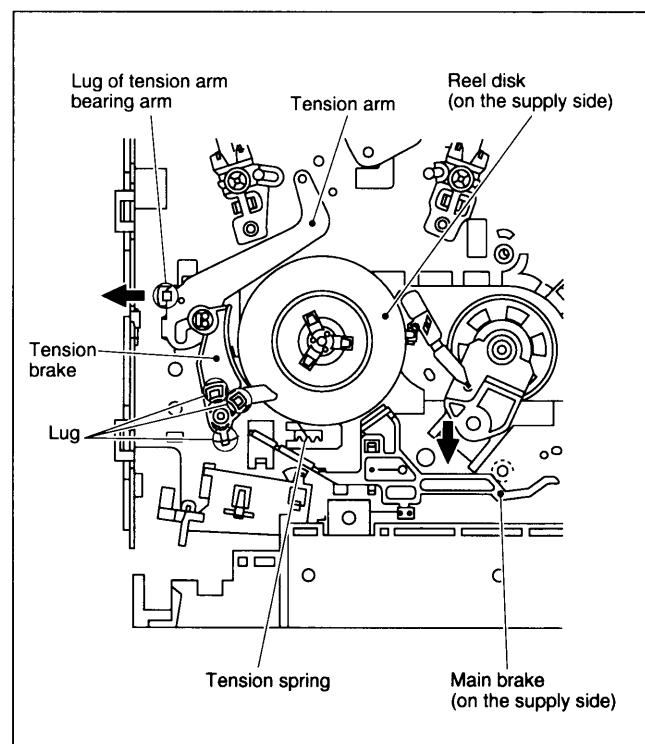

Fig. 2-2-34

**2.2.23 Idler Lever, Idler Arm and Reel Shaft**

- (1) Remove one lug of the idler lever from the main deck and remove the hook fitted in the idler arm hole by lifting it.
- (2) Remove the slit washer and pull out the idler arm.
- (3) Turn the reel shaft counterclockwise through 60 degrees and remove it. (See Fig.2-2-35)

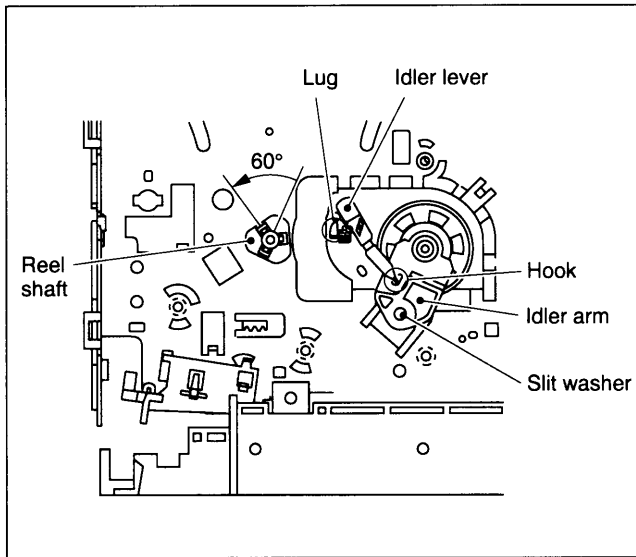

Fig. 2-2-35

**2.2.24 Stator Assembly**

- (1) Remove two screws (A).
- (2) Remove the stator assembly by lifting in the arrow-indicated direction (Take care that the brush spring does not jump out).
- (3) Remove the flat cable.
- (4) After installation, be sure to perform the 3.2.1 PB switching point adjustment according to the electrical adjustment procedure.

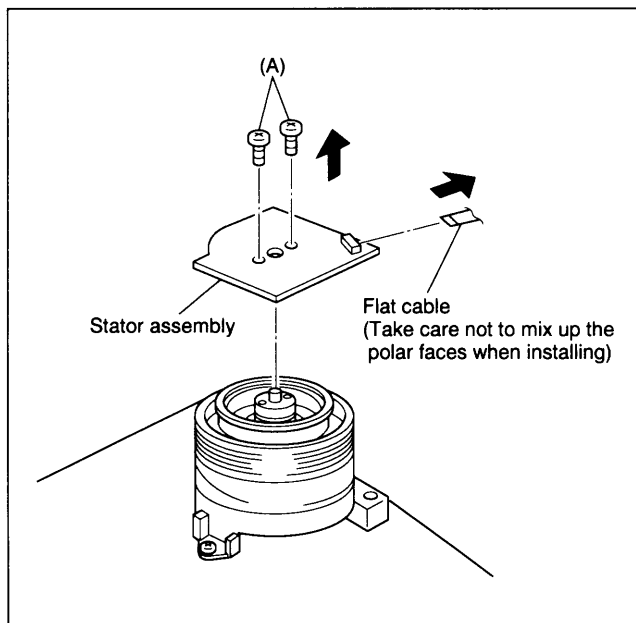

Fig. 2-2-36

**2.2.25 Rotor Assembly**

- (1) Remove the stator assembly.
- (2) Remove the two screws (B) and remove the rotor assembly.

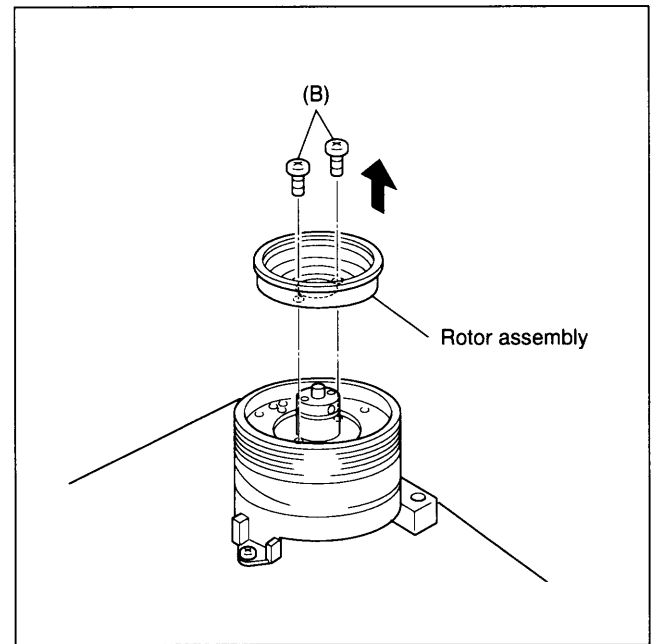

Fig. 2-2-37

**Note:** When installing the rotor assembly, note that a normal picture cannot be obtained without ensuring the phase matching as mentioned below.

- (3) Match the phases of the upper drum and the rotor assembly as indicated in Fig.2-2-38.
- (4) Place the upper drum hole (a) over the rotor assembly holes (b) (with three holes to be aligned) and tighten the two screws (B). (See Fig.2-2-38)

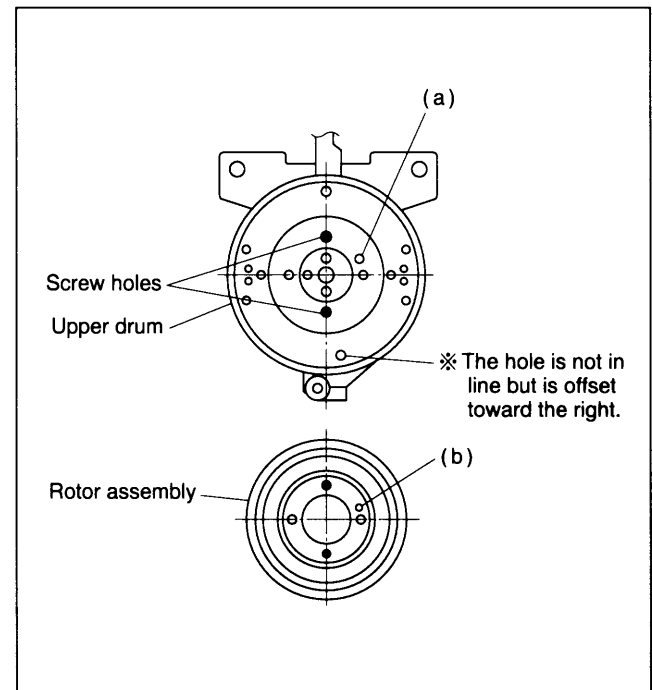

Fig. 2-2-38

## 2.2.26 Upper Drum Assembly

### 1. How to remove

- (1) Remove the stator assembly and rotor assembly. (See Fig. 2.2.36 and Fig. 2.2.37)
- (2) Loosen the screw of the collar assembly using a 1.5 mm hexagonal wrench and remove the collar assembly. Also remove the brush, spring and cap at one time.
- (3) Remove the upper drum assembly and remove the washer using tweezers.

**Note:** When replacement is required, control the up-down movement of the brush. Never apply grease.

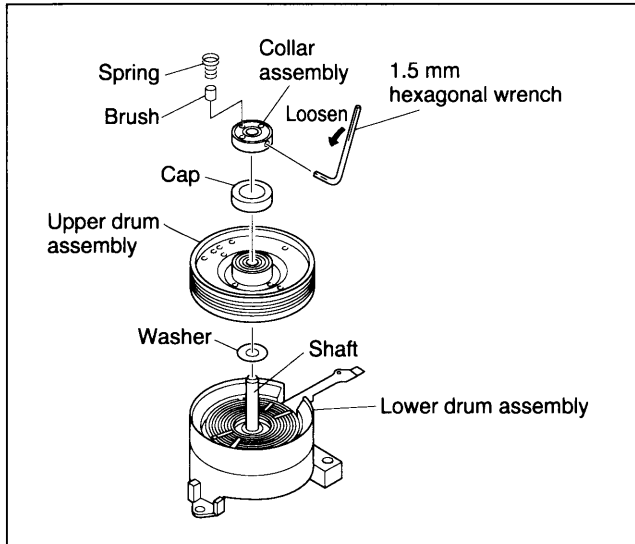

Fig. 2-2-39 Upper drum assembly-1

### 2. How to install

- (1) Clean coil parts of the lower drum assembly and the newly installed upper drum assembly with an air brush in advance. (See Fig.2-2-40).
- (2) Install a new washer and upper drum assembly on the drum shaft. (See Fig.2-2-39)

**Note:** When replacing the upper drum assembly, replace it together with the washer.

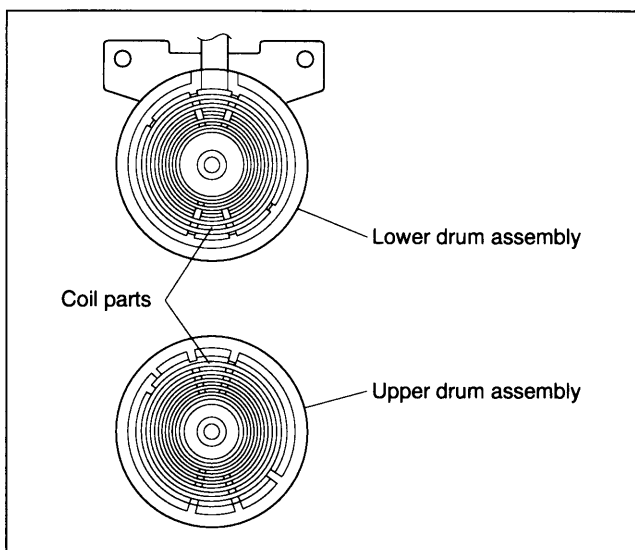

Fig. 2-2-40

- (3) Position the collar assembly as indicated in Fig.2-41 while controlling its up-down movement.

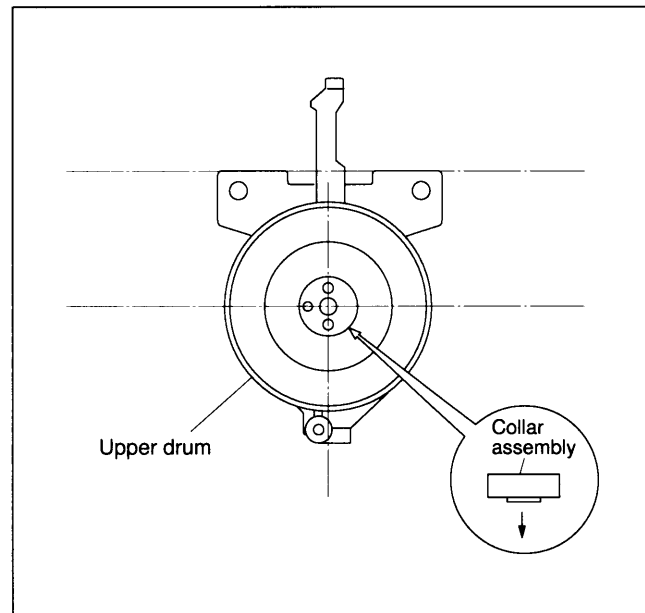

Fig. 2-2-41

- (4) Secure the collar assembly in position with a hexagonal wrench while pressing its top with the fingers.

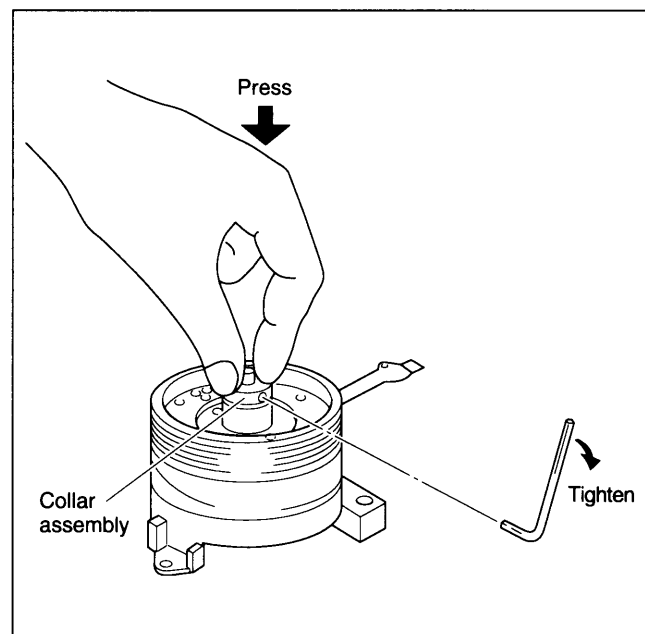

Fig. 2-2-42

- (5) After installation, gently turn the upper drum with your hand to make sure that it turns normally.
- (6) Install the rotor assembly and stator assembly according to Fig. 2.2.36 and Fig. 2.2.38.
- (7) When installation is complete, clean the upper drum assembly and lower the drum assembly and carry out the following adjustments.
  - PB switching point adjustment
  - Slow tracking adjustment
  - Compatibility adjustment

## 2.3 MAJOR PARTS INSTALLATION (PHASE MATCHING BETWEEN MECHANICAL PARTS)

### 2.3.1 Before Assembly of the Parts

The mechanism of this unit is closely linked with the rotary encoder and system controller circuits.

Since the system controller detects the status of mechanical operation in response to phases of the rotary encoder (internal switch positions), the mechanism may not operate properly unless such parts as the rotary encoder, control plate, loading arm assembly, control cam, cassette gear, limit gear, relay gear and drive gear are installed in their correct positions.

Especially, this model is not provided with any cassette housing assembly, so that cassette loading and unloading must be accomplished by operation of the cassette holder assembly. The latter is in turn driven by such parts as drive gear, relay gear and limit gear. Exercise enough care, therefore, to have the phases of all this gear matching one another.

Perform the installation of major parts (including phase matching) in the mechanism assembling mode as in the previous section.

### 2.3.2 Loading Arm Assembly (on the Supply or Take-up Side)

- (1) Return the pole base assembly to the foremost position in the unloading direction.
- (2) Install the loading arm assembly so that the register mark on the gear of the supply side loading arm is in alignment with the one on the take-up side loading arm as indicated in Fig. 2-3-1.

See 2.2.16 "2. How to install" of the foregoing section for details of installation.

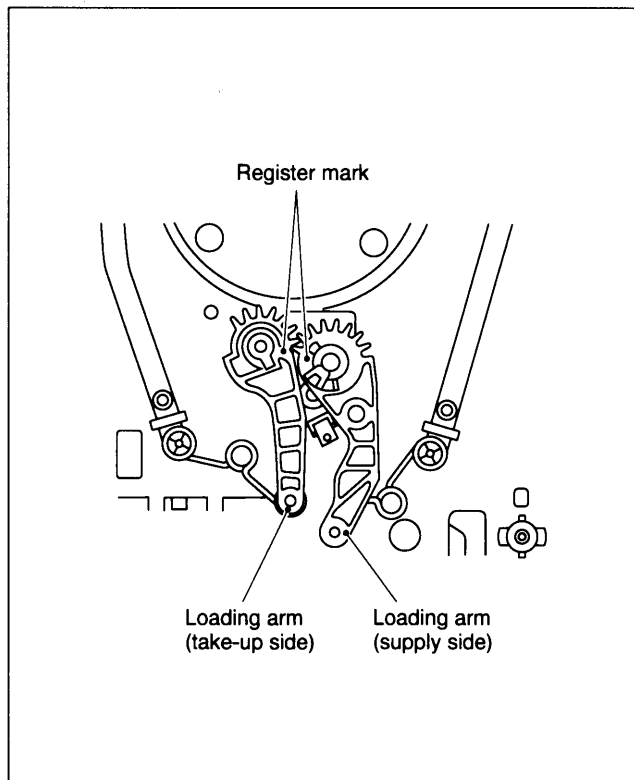

Fig. 2-3-1

### 2.3.3 Control Plate

- (1) With register marks on the both loading arm assemblies in alignment, install the control plate so that the mark ▼ on the loading arm gear shaft is in alignment with mark E of the control plate. (See Fig.2-3-2)  
See 2.2.15 "2. How to install" of the foregoing section for details of installation.

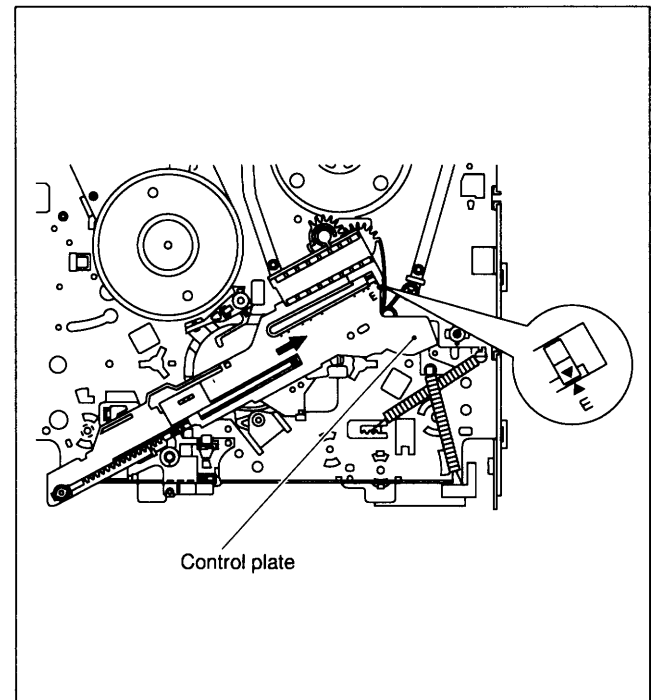

Fig. 2-3-2

### 2.3.4 Rotary Encoder

- (1) Make sure that the mark E of the control plate is in alignment with the mark ▼ of the loading arm gear shaft and bring the register marks on the rotary encoder into alignment as indicated in Fig.2-3-3.
- (2) Turn over the rotary encoder with its register marks kept in alignment and install it by fitting on the shaft of the rotary encoder guide and the positioning pin.
- (3) Tighten the screw (A) to complete the installation.

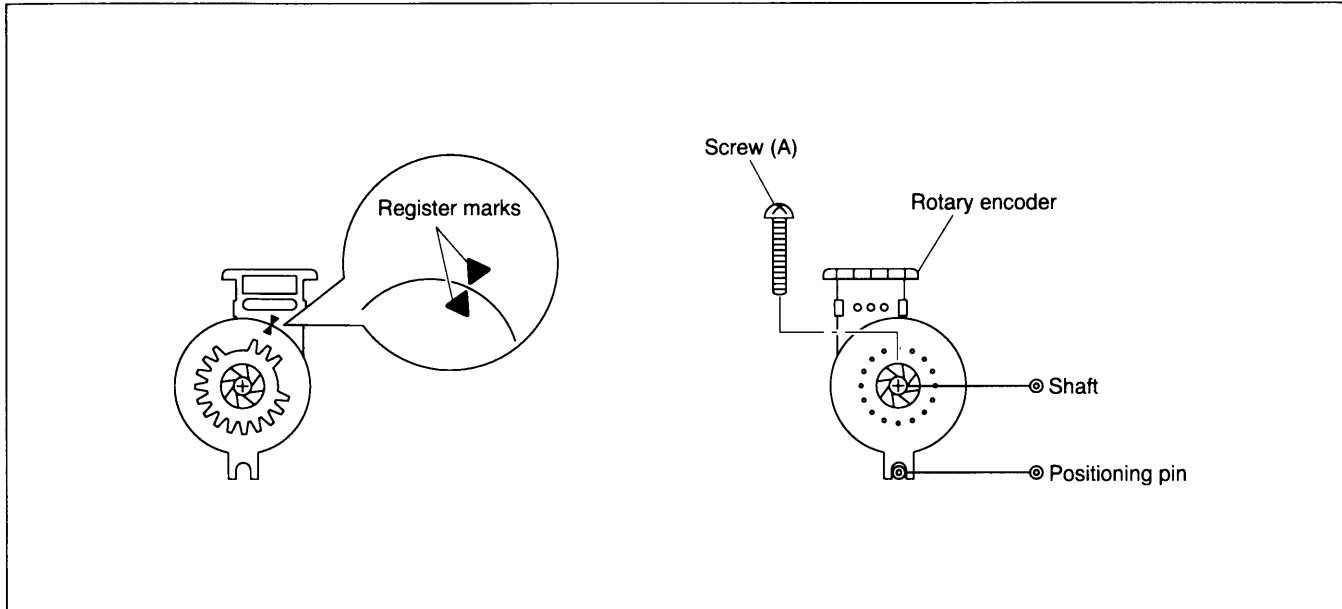

Fig. 2-3-3

**2.3.5 Control Cam, Cassette Gear and Link Lever**

- (1) Install the control cam as indicated in Fig.2-3-4 making sure of the front and back side alignment.  
Note here that the register hole of the control cam is in alignment with and allows passage through the register hole of the main deck. Perform fine-adjustment by turning the worm gear.
- (2) Install the cassette gear by pushing it until it is locked with a clicking sound. (See Fig.2-3-4)
- (3) Insert section (A) of the link lever into section (B) of the control plate as shown in Fig.2-3-5.

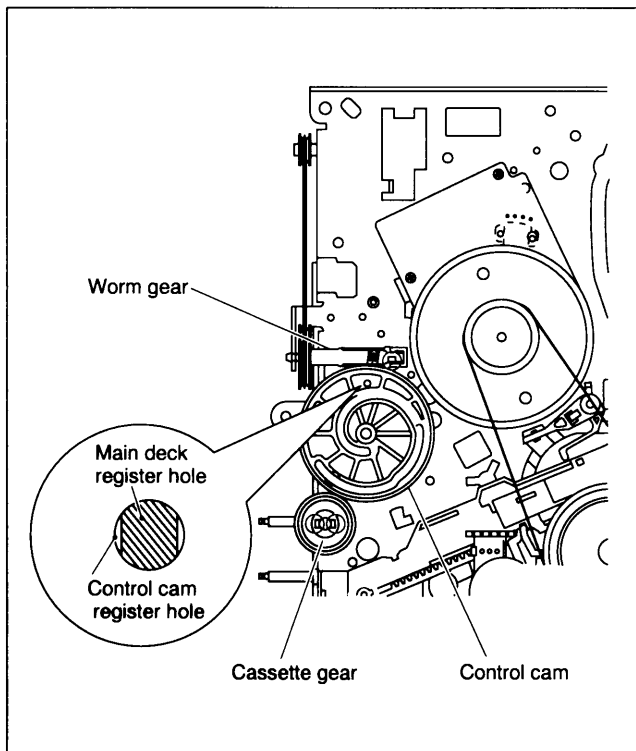

Fig. 2-3-4

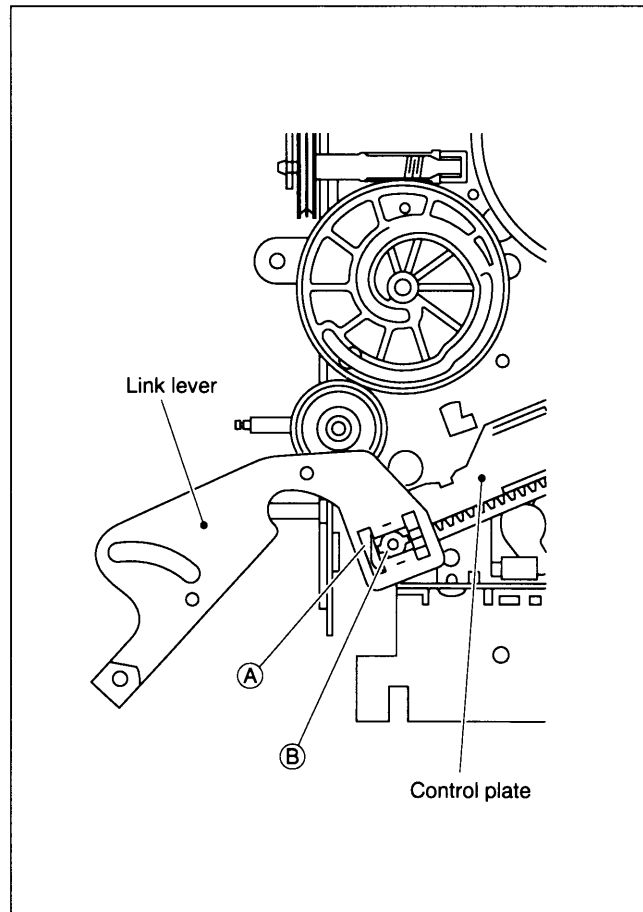

Fig. 2-3-5

- (4) Turn the link lever clockwise and mount it on the control cam center shaft (A) and the control cam left-side shaft (B). (See Fig.2-3-6).
- (5) Fasten the slit washers at two points (A) and (B).

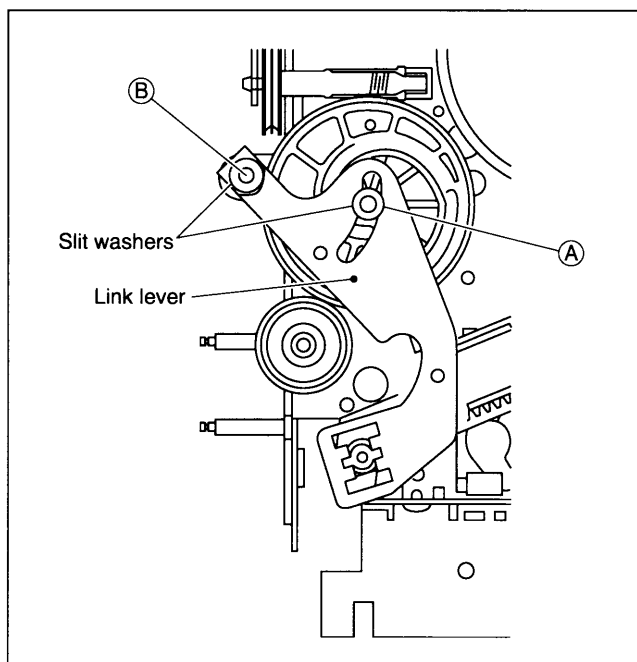

Fig. 2-3-6

### 2.3.6 Relay Gear, Limit Gear and Drive Gear

- (1) Install the limit gear so that the notch at its outer circumference is in alignment with the register hole of the main deck. (See Fig.2-3-7)
- (2) Install so that the notch at the outer circumference of the relay gear is in alignment with the notch of the main deck, and at the same time, that the hole A of the relay gear is in alignment with hole A of the limit gear and hole B of the relay gear with hole B of the drive gear. (See Fig.2-3-7)

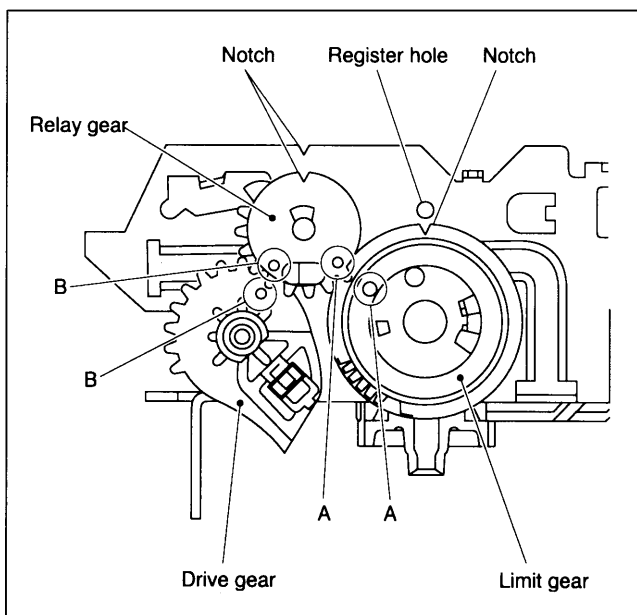

Fig. 2-3-7

## 2.4 COMPATIBILITY ADJUSTMENT

- Notes:**
- Although compatibility adjustment is very important, it is not necessary to perform this as part of the normal servicing work. It will be required when you have replaced the audio control head, drum assembly or any part of the tape transport system.
  - To avoid any damage to the alignment tape while performing the compatibility adjustment, get a separate cassette tape (for recording and play back) ready to be used for checking the initial tape running behavior.

### 2.4.1 Checking/Adjustment of FM Waveform Linearity

- (1) Connect the oscilloscope to TP106(PB FM/COL) of the main board assembly and to TP111(D.FF) of the main board assembly for external sync connection.
- (2) Playing the alignment tape SP, observe the FM waveform.
- (3) Press the channel buttons (▲) and (▼) buttons simultaneously during playback to enter the manual tracking mode (This also brings tracking to the center.)
- (4) Make sure that there is no significant level drop of the FM waveform caused by the tracking operation, with its generally parallel and linear variation ensured. Perform the following adjustments when required. (Fig.2-4-1)
- (5) Slightly loosen the set screw under the pole base assembly with a 1.25 mm hexagonal wrench (Take care not to loosen too much). (Fig.2-4-2)
- (6) Reduce the FM waveform while pressing the channel buttons (▲, ▼) during playback. If a drop in level is found on the left side as shown in Fig.2-4-3, turn the guide roller of the pole base assembly (supply side) with the roller driver to make the FM waveform linear. If a drop in level is on the right side, likewise turn the guide roller of the pole base assembly (take-up side) with the guide roller to make it linear. (Fig.2-4-3)
- (7) Then play alignment tape (LP) and make sure that the FM waveform varies in parallel and linearly with the tracking operation. When required, perform fine-adjustment of the guide roller of the pole base assembly (supply or take-up side).
- (8) After adjustment, tighten the set screw under the pole base assembly. (Take care not to tighten too much)
- (9) After tightening the set screw, play the alignment tape (SP) and (LP) again to make sure that the FM waveform has correct variation.

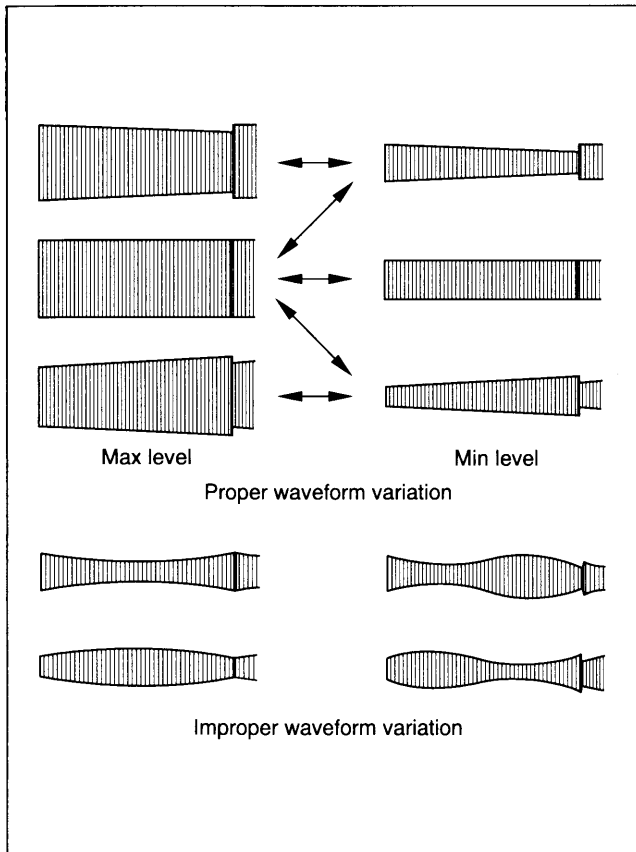

Fig. 2-4-1

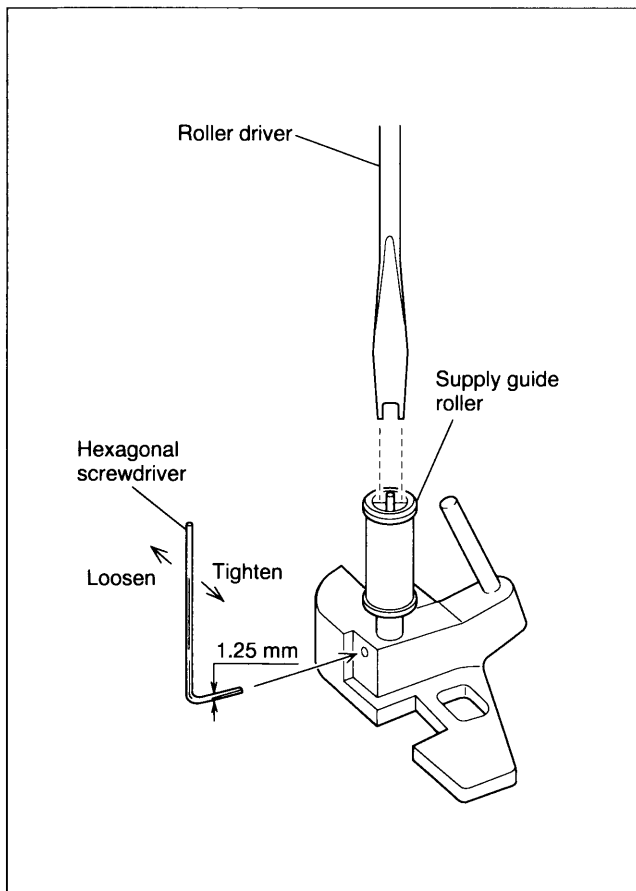

Fig. 2-4-2

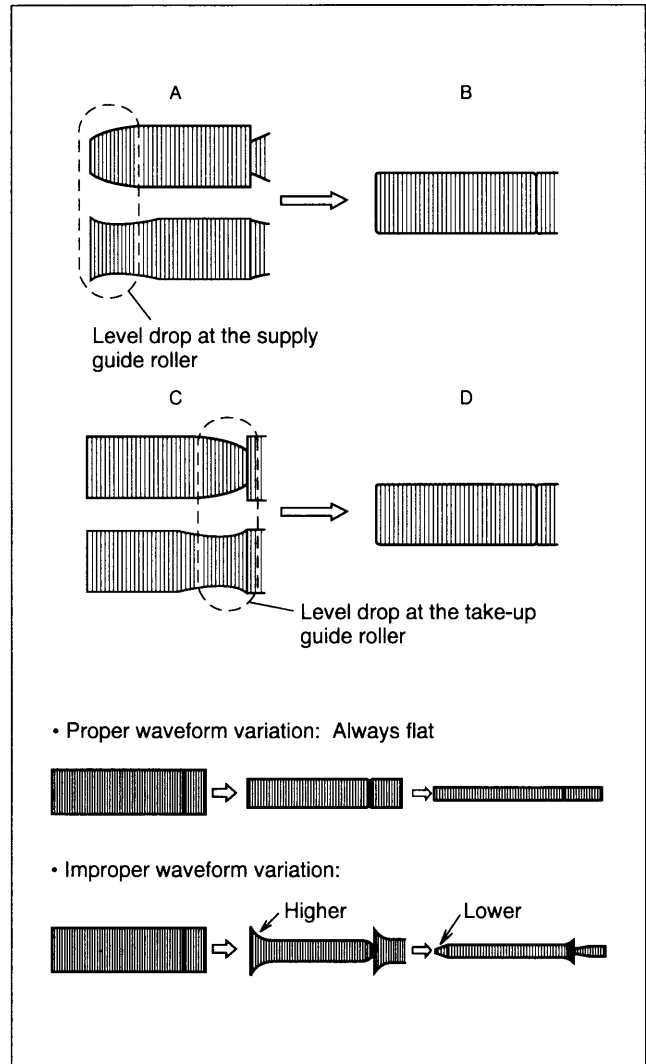

Fig. 2-4-3

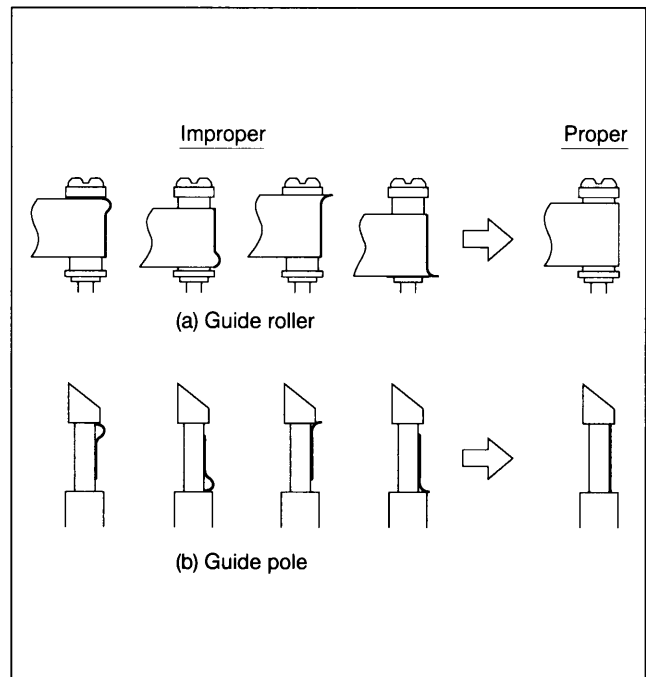

Fig. 2-4-4



**2.4.2 Checking/Adjustment of the Height and Tilt of the Audio Control Head**

**Note:** Set a temporary level of the height of the A/C head in advance to make the adjustment easier. (See Fig.2-2-14)

- (1) Connect CH-1 of the oscilloscope to AUDIO OUT and CH-2 to TP4001 (CTL P) of the main board and observe the waveforms on both channels in the ALT mode.
- (2) Play the alignment tape (SP) and adjust it by turning screws (1), (2) and (3) little by little until the waveform of both the audio output signal and the control pulse reach maximum. Screw (1) and screw (3) are for adjustment of tilt and screw (2) for azimuth.

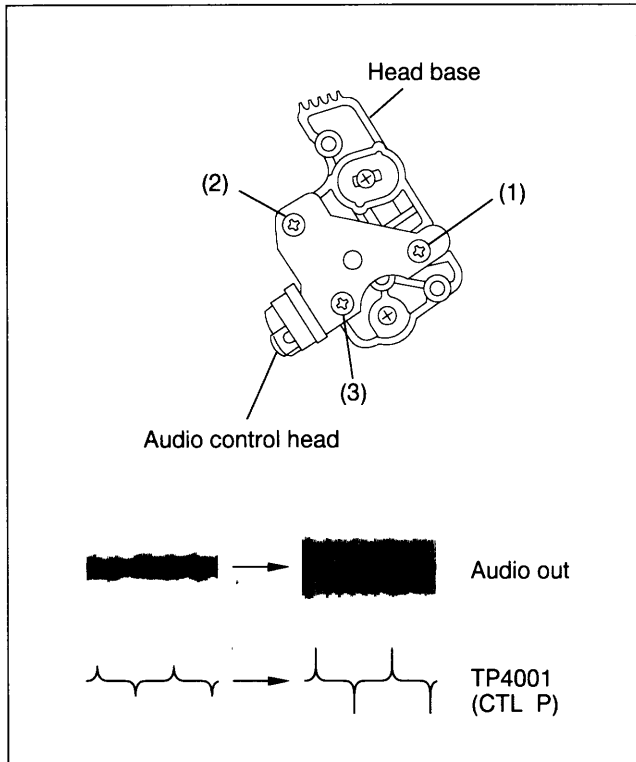

Fig. 2-4-5

**2.4.3 Checking/Adjustment of the Audio Control Head Phase (X-Value)**

- (1) Connect the oscilloscope to TP106(PB FM/COL) of the main board assembly and to TP111(D.FF) of the main board assembly for external sync connection.
- (2) Play the alignment tape (SP) and observe the FM waveforms.
- (3) Press the channel buttons (▲) and (▼) buttons simultaneously during playback to enter the manual tracking mode (This also brings tracking to the center.)
- (4) Loosen screws (4) and (5) so that the A/C head position bit is set as indicated in Fig.2-4-6.
- (5) Turn the A/C head position and first move the audio control head fully up to the capstan head. Then gradually return the audio control head toward the drum and stop it where the FM waveform reaches its maximum for the first time. Then tighten screw (4) temporarily.

- (6) Then play the alignment tape (LP).
- (7) Press the channel buttons (▲) and (▼) buttons simultaneously during playback to enter the manual tracking mode (This also brings the tracking to the center.)
- (8) Perform the tracking operation and make sure that the FM waveform is at its maximum.
- (9) If it is not at maximum, loosen the temporarily tightened screw (4) and turn the A/C head position bit to bring the audio control head to a position, around where the waveform reaches its maximum for the first time. Then tighten screws (4) and (5).

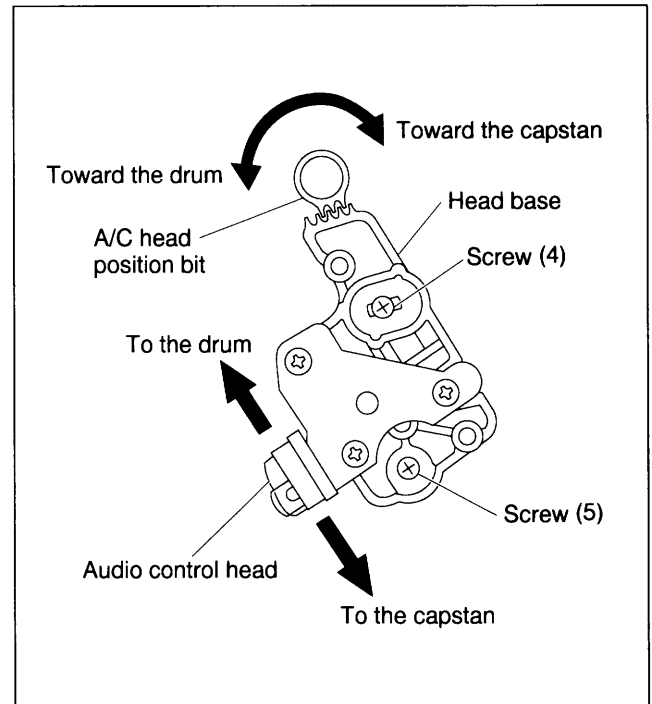

Fig. 2-4-6

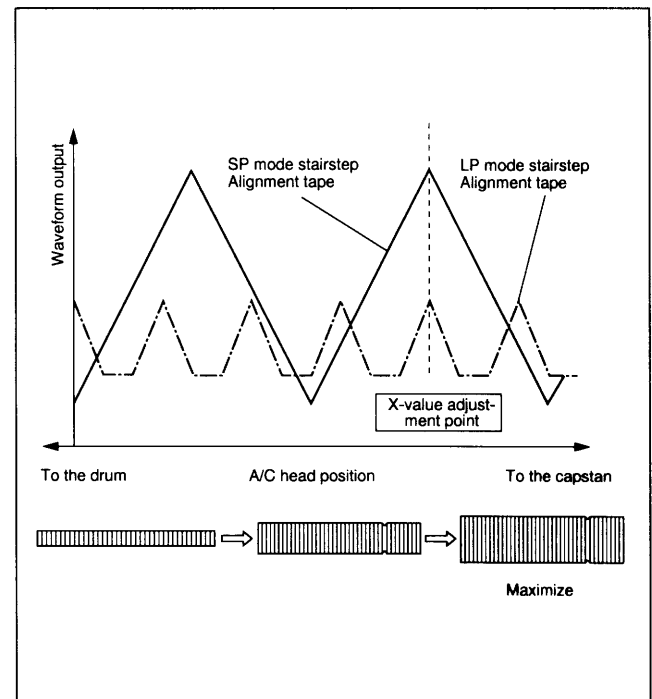

Fig. 2-4-7

#### 2.4.4 LP mode Tracking Preset

**Note:** Depress button "A" on presetting unit to VCR to "code receive" mode.

- (1) Connect the oscilloscope to TP106(PB FM/COL) of the main board assembly and to TP111(D.FF) of the main board assembly for external sync connection.
- (2) Playing the alignment tape (LP) and observing the FM waveform, make sure that the auto tracking operation is complete.
- (3) Press the button "D" of the presetting unit twice.
- (4) Make sure that the alignment tape (LP) is not ejected.
- (5) If ejected, again perform the phase (X-value) adjustment of the audio control head.

#### 2.4.5 Checking/Adjustment of the Tension Pole

- (1) Check the back tension cassette gauge to make sure that the indicator points to 29 - 46 g-cm.
- (2) If the indicated value is outside this range, carry out the following adjustment steps.
  - 1) Select the mechanism servicing mode. (See 1.5 MECHANISM SERVICE MODE)
  - 2) While in the Play mode, turn the adjustment pin with a straight-slot screwdriver. (See Fig.2-4-8).

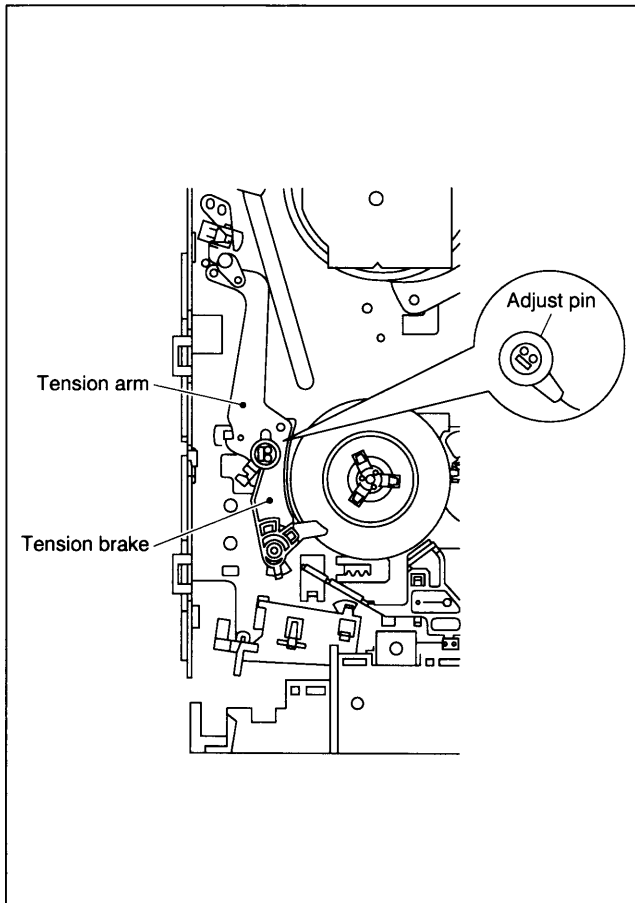

Fig. 2-4-8

#### 2.4.6 Adjustment of the Tension Stud

- (1) Adjust so that the left side of the tension stud is on the extension of the notch line of the main deck as indicated in Fig.2-4-9.

**Note:** Adjustment is not usually necessary for the tension stud. Perform this adjustment only when it is out of position.

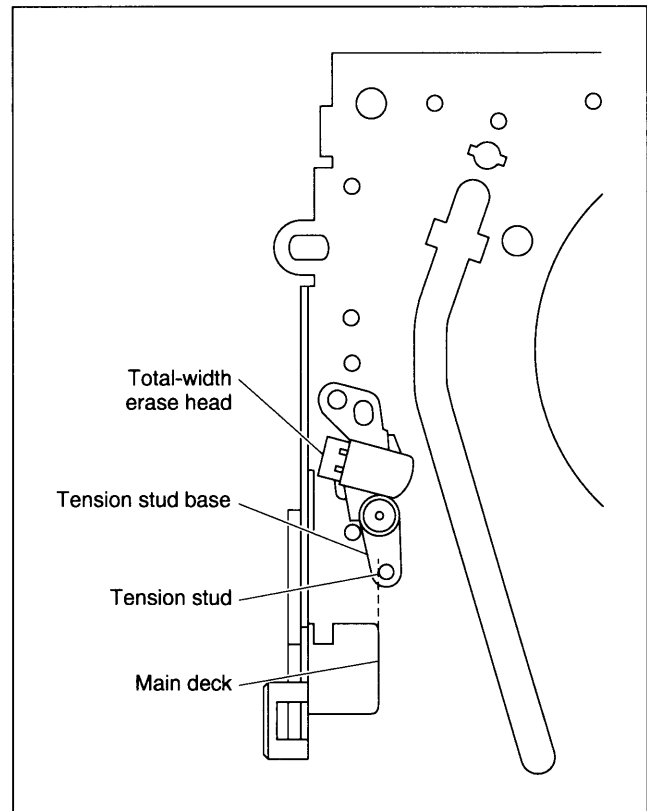

Fig. 2-4-9

#### 2.4.7 Main Brake Torque Adjustment

**Note:** Adjustment of the main brake torque is required after the adjustment pin has been removed or the main brake or the reel base on the supply or take-up side have been replaced, removed or attached.

- (1) Rotate the pulley of the loading motor by hand to align the mark ▼ on the loading arm gear shaft with the ST marking on the control plate (i.e. set to the STOP mode position).
- (2) Insert a torque gauge into the reel base on the side to be played, hold the torque gauge lightly, rotate it clockwise when measuring the supply side torque or counterclockwise when measuring the take-up side torque, and read the value indicated at the moment the reel base starts to slip.
- (3) Make sure that the main brake torque values on the supply and take-up sides are both between  $39.2 - 78.4 \times 10^{-3} \text{ N-m}$  (400 — 800 gf-cm). If the value is outside the specified range, adjust to the specified value by rotating the adjustment pin.

If an adjustment by using the adjustment pin is not possible, replace the main brake.

## How to Mount the Capstan Motor (Centering the Mounting Position)

When the capstan motor has once been removed and then reinstalled out of the initial correct position in the rotational direction, the capstan motor current may be unstable during operation in high or low temperatures. This may result in greater Wow & Flutter and occasionally in power breakdown because of current over - load. Install the capstan motor while following the procedure given below.

(The capstan motor is centrally located when the unit is shipped from the factory.)

1. Provisionally tighten the three screws (A) securing the capstan motor.

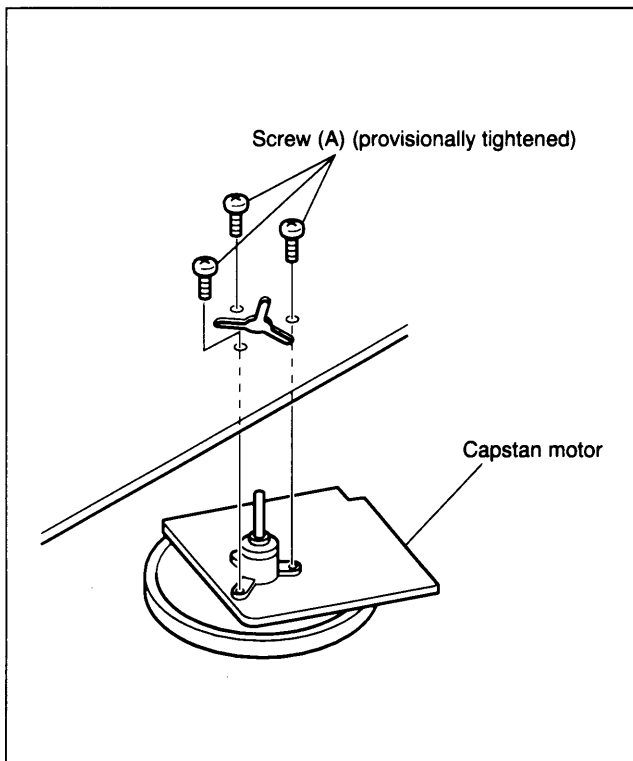

2. Install the mechanism to which the capstan motor is provisionally fastened on the bottom chassis which incorporates the Main board assembly. (No need to tighten the screws for mounting the mechanism)  
Make sure that all the connectors for the mechanism and the Main board are correctly installed.

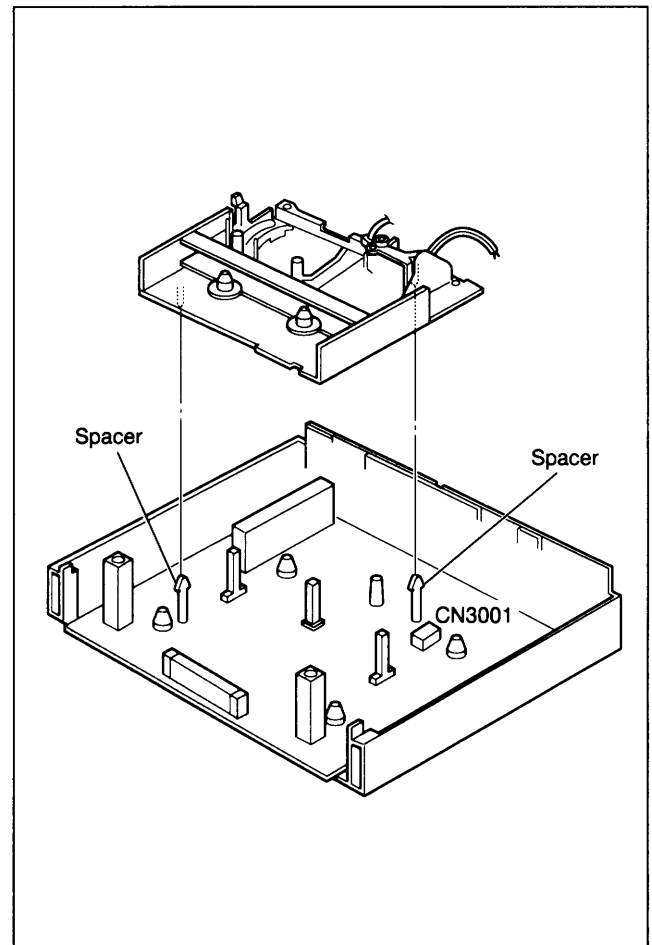

3. Securely tighten the three screws (A), especially making sure that the connector CN3001 of the capstan motor is correctly mounted.

**Note:** *When the capstan motor has been replaced with a new one, perform recording in the LP mode for at least 2 minutes at normal temperatures immediately before starting the FF/REW or SEARCH operations (Aging).*

### Mechanism Timing Chart

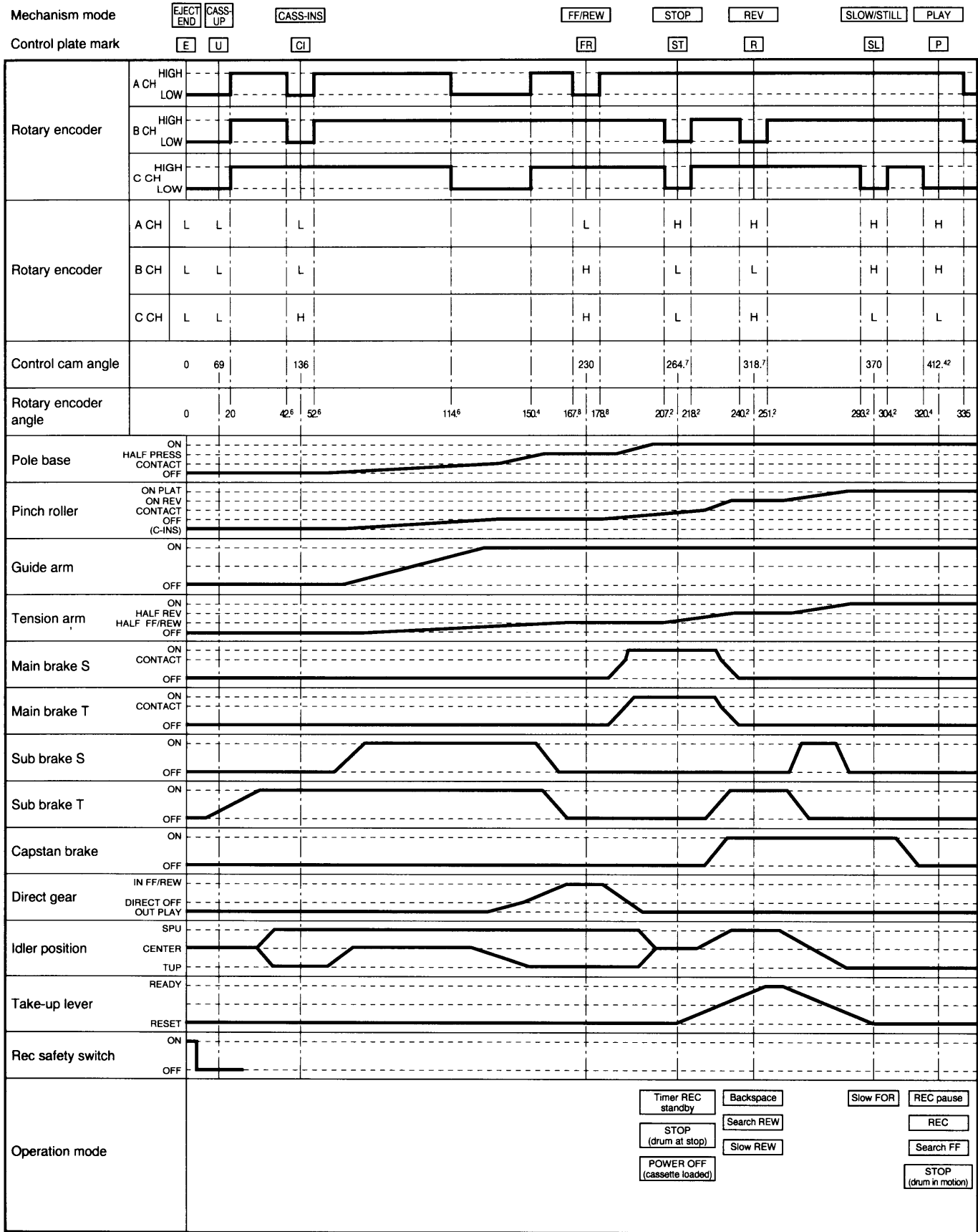

# Electrical Adjustment

## 3.1 PRECAUTION

Electrical adjustment are required after replacing circuit components and certain mechanical parts. It is important to perform these adjustments only after all repairs and replacements have been completed. Also do not attempt these adjustments unless the proper equipments is available.

### 3.1.1 Required test equipment

- ① Colour television or monitor
- ② Oscilloscope: wide-band,dual-trace,triggered delayed sweep
- ③ Frequency counter
- ④ Digital voltmeter
- ⑤ Signal generator: RF/IF sweep/maker
- ⑥ Signal generator: PAL/SECAM colour bar, stairstep
- ⑦ Recording tape
- ⑧ Numeric-key remote controller(provided)

### 3.1.2 Required adjustment tools

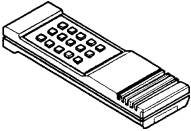
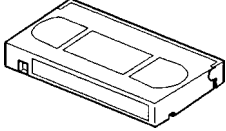
Presetting unit 75981 311 2600	Alignment tape 75981 311 2700
	

**Note:**

*Be sure to remove the R3229 and install the R3228 (100K) when replacing the SYSTEM CONTROLLER IC (IC3001 on the MAIN PWB ASS'Y) and EEPROM (IC3004 on the MAIN PWB ASS'Y).*

## 3.1.3 Colour bar signal,colour bar pattern

● PAL colour bar signal

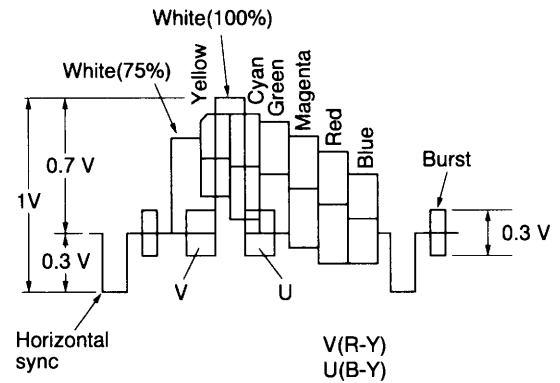

Fig.3-1-1 PAL colour bar signal waveform

● PAL colour bar pattern

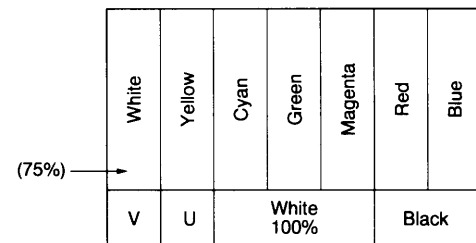

Fig.3-1-2 PAL colour bar pattern

### 3.2 SERVO CIRCUIT

- Notes:**
- Unless otherwise specified, all measurement point and adjustment parts are located on the MAIN BOARD.
  - Depress button "A" on presetting unit to VCR to "code receive" mode.

#### 3.2.1 PB switching point

Signal	• Alignment tape [SP], Stairstep
Mode	• PB
Equipment	• Oscilloscope
Measurement point	• VIDEO OUT TERMINAL
Trigger slope (-)	• TP111(DRUM FF)
Adjustment tool	• Presetting unit
Specification	• $6.5 \pm 0.5H$

- (1) Connect an oscilloscope to VIDEO OUT TERMINAL and external trigger from TP111 (negative slope).
- (2) Playback the stairstep signal of the alignment tape.
- (3) Press the "O" button of the presetting unit.
- (4) The adjustment is performed automatically.

Once the adjustment is performed, the VCR will go into the STOP mode.

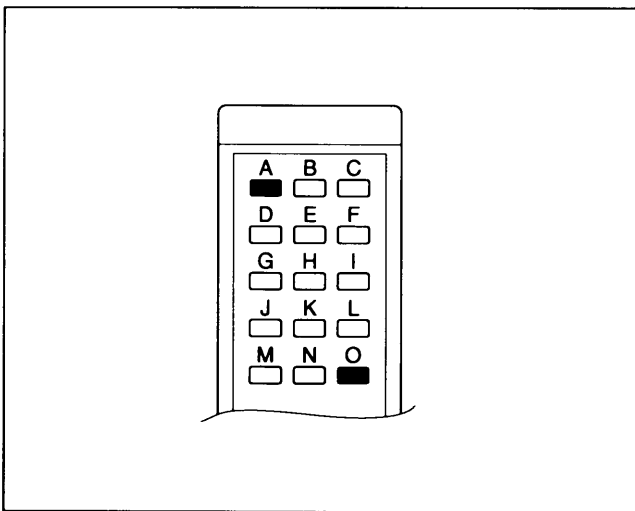

Fig.3-2-1 Presetting unit

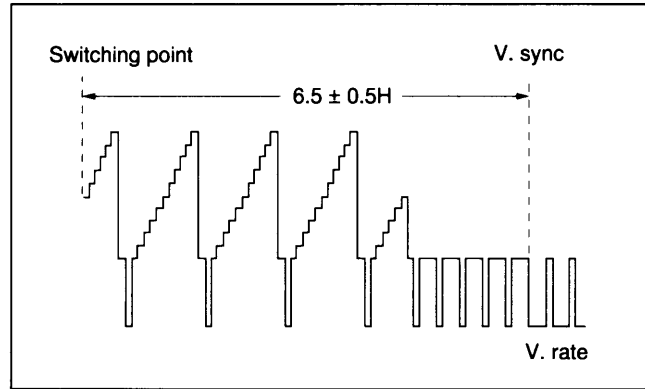

Fig.3-2-2 PB switching point

#### 3.2.2 Slow tracking preset

Signal	• Colour bar (PAL, NTSC)
Mode	• SP: PAL REC → PB(SLOW) • SP: NTSC
Equipment	• TV-Monitor
Adjustment tool	• Presetting unit
Specification	• Minimum noise

- Notes:**
- Depress button "A" on presetting unit to VCR to "code receive" mode.
  - Use only buttons "B" and "C", depressing other buttons during adjustment may cause adjustment errors.

- (1) Record a PAL colour bar signal in the SP mode.
- (2) Playback recorded signal on the FWD slow mode.
- (3) Observe the display on the TV monitor and adjust for optimum noise condition (best tracking) by depressing "B" or "C" buttons of the presetting unit.
- (4) Depress the STOP button.
- (5) Confirm that the bar noise is not visible on the TV monitor in the slow mode.
- (6) Repeat steps (1) to (5) in the NTSC mode.

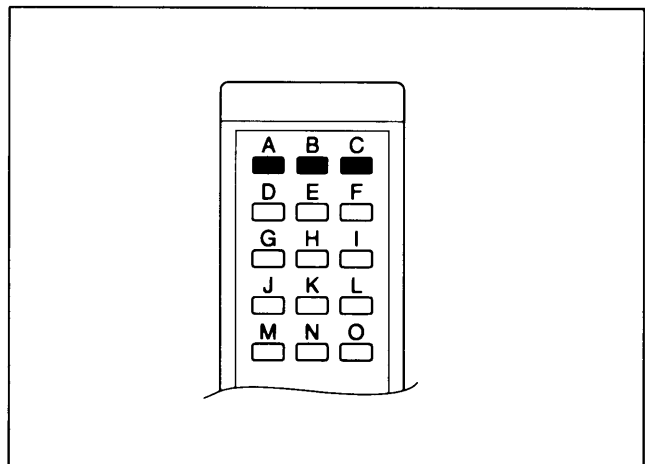

Fig.3-2-3 Presetting unit

### 3.3 VIDEO CIRCUIT

- Notes:**
- Unless otherwise specified, all measurement point and adjustment parts are located on the MAIN BOARD.
  - Depress button "A" on presetting unit to VCR to "code receive" mode.

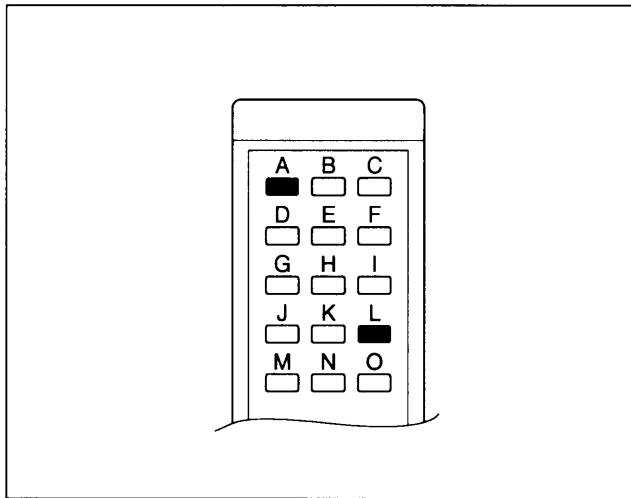

Fig.3-3-1 Presetting unit

#### 3.3.1 Auto picture

Signal	• Monoscope
Mode	• REC then PB • SP/LP: PAL • SP/EP: NTSC • BEST: OFF
Adjustment tool	• Presetting unit
Specification	• STOP mode

- (1) Set B.E.S.T feature to OFF on MENU screen.
- (2) Record a monoscope signal in the SP mode.
- (3) Playback the recorded signal.
- (4) Press the "L" button of the presetting unit during playback.
- (5) Confirm that VCR will go into the STOP mode.
- (6) Repeat steps (3) to (5) in the LP mode.
- (7) Repeat steps (2) to (6) in the NTSC mode.

### 3.4 SYSCON CIRCUIT

- Notes:**
- Unless otherwise specified, all measurement point and adjustment parts are located on the MAIN BOARD.
  - When perform this adjustment, remove the MECHANISM assembly.

#### 3.4.1 Timer clock

Signal	• No signal
Mode	• EE
Equipment	• Frequency counter
Measurement point	• IC3001 73PIN
Adjustment part	• C3018 (TIMER CLOCK)
Specification	• 8192.057 – 8192.074 Hz [122.0692 – 122.0695 μsec]

- (1) Connect the frequency Counter to Pin No.73 of the IC3001 and GND.
- (2) Connect Pin No.71 of the IC3001 to GND.
- (3) Short-circuit both ends of the C3015 once to reset the IC3001.
- (4) Disconnect Pin No. 71, which was connected to GND at Step (2).
- (5) Adjust the C3018 trimmer capacitor so that the output from Pin No.73 of the IC3001 falls within 8192.057 to 8192.074 Hz (122.0692 to 122.0695 μsec) range.

### 3.5 ON SCREEN CIRCUIT

- Notes:**
- Unless otherwise specified, all measurement point and adjustment parts are located on the MAIN BOARD.
  - Depress button "A" on presetting unit to VCR to "code receive" mode.

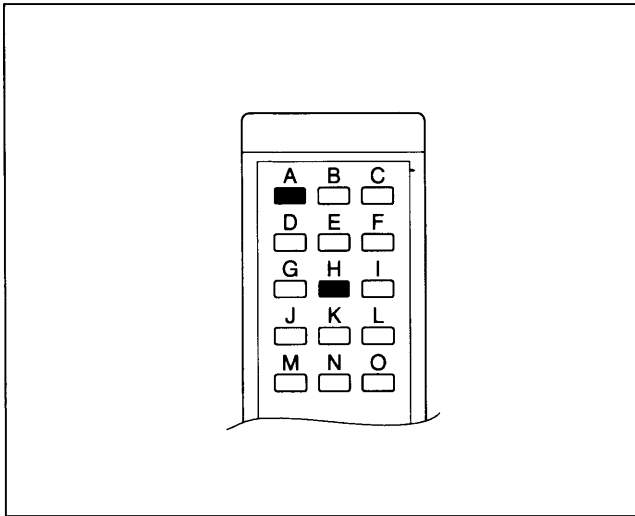

Fig.3-5-1 Presetting unit

#### 3.5.1 Character position

Signal	• No signal
Mode	• EE
Equipment	• TV-monitor
Adjustment tool	• Presetting unit
Specification	• Character centre

- (1) Press the MENU button and display the on screen character.
- (2) Press "H" button on the presetting unit.
- (3) Adjust CH "+" or "-" button so that the character is centre position.
- (4) Press the TIMER button on remote controller to change the indications of "0E" and "0F" on the FDP.
- (5) Press "H" button on the presetting unit again to return to normal mode.

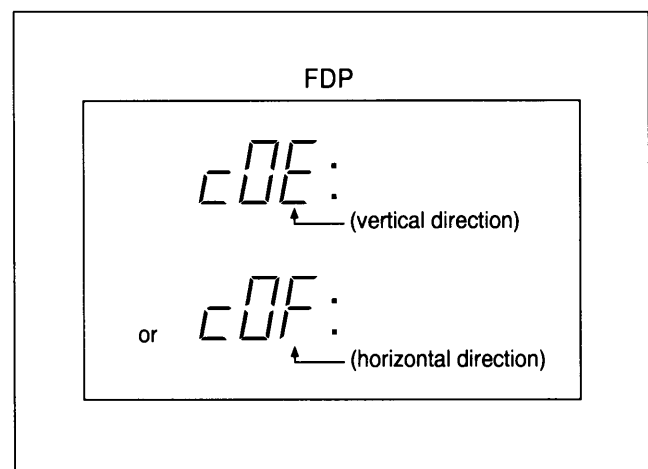

Fig.3-5-2 FDP



# Layout of PCBs and Circuit Diagrams

## NOTES OF SCHEMATIC DIAGRAM

**Safety precautions**  
 The Components identified by the symbol are critical for safety. For continued safety, replace safety critical components only with manufacturer's recommended parts.

### 1. Units of components on the schematic diagram

Unless otherwise specified.

- 1) All resistance values are in ohm, 1/6 W, 1/8 W (refer to parts list).  
Chip resistors are 1/16 W.  
K: K $\Omega$  (1000 $\Omega$ ), M: M $\Omega$  (1000K $\Omega$ )
- 2) All capacitance values are in  $\mu$ F, (P: PF).
- 3) All inductance values are in  $\mu$ H, (m: mH).
- 4) All diodes are 1SS133, MA165 or IN4148M (refer to parts list).

### 2. Indications of control voltage

AUX : Active at high

AUX or AUX(L) : Active at low

### 3. Interpreting Connector indications

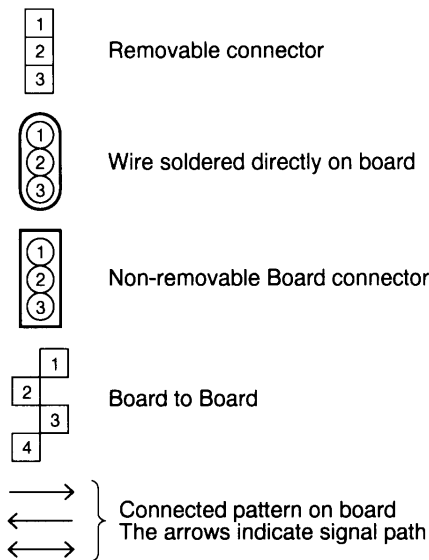

### 4. Voltage measurement

- 1) Video circuits  
REC : Colour bar signal in SP mode, normal VHS mode  
PB : Alignment tape, colour bar SP mode, normal VHS mode  
— : Unmeasurable or unnecessary to measure
- 2) Audio circuits  
REC : 1KHz, -8 dBs sine wave signal in SP mode, Normal VHS mode  
PB : REC then playback it
- 3) Movie Camera circuits  
Measured using a correctly illuminated gray scale or colour bar test charts in the E-E mode

- 4) Indication on schematic diagram  
Voltage Indications for REC and PB mode on the schematic diagram are as shown below.

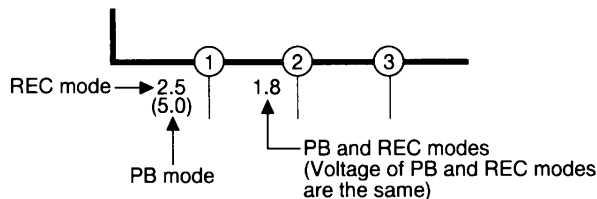

**Note: If the voltages are not indicated on the schematic diagram, refer to the voltage charts.**

### 5. Waveform measurement

- 1) Video circuits  
REC : Colour bar signal in SP mode, normal VHS mode  
PB : Alignment tape, colour bar SP mode, normal VHS mode
- 2) Audio circuits  
REC : 1KHz, -8 dBs sine wave signal in SP mode, normal VHS mode  
PB : REC then playback it
- 3) Movie Camera circuits  
Measured using a correctly illuminated gray scale or colour bar test charts in the E-E mode
- 4) Indication on schematic diagram  
Waveform indications on the schematic diagram are as shown below.

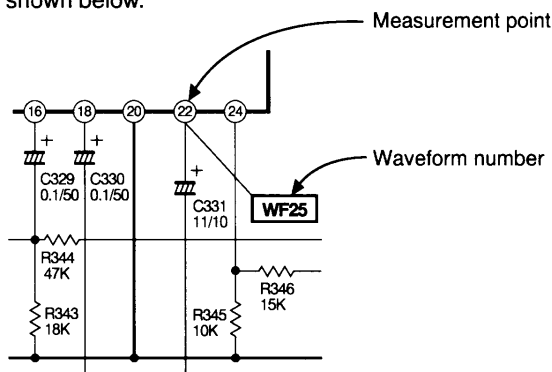



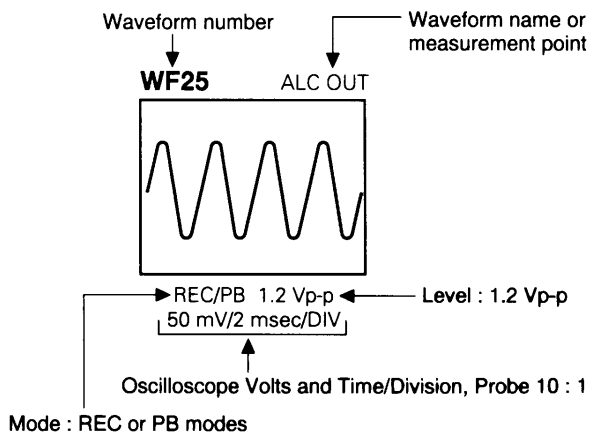

### 5) Waveform indications





**6. Signal path Symbols**

The arrows indicate the signal path as follows.

-  Playback signal path
-  Playback and recording signal path
-  Recording signal path (including E-E signal path)
-  Capstan servo path
-  Drum servo path

(Example)

-  R-Y Playback R-Y signal path
-  Y Recording Y signal path

**7. Indication of the parts for adjustments**

The parts for the adjustments are surrounded with the circle as shown below.

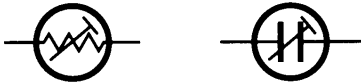

**8. Indication of the parts not mounted on the circuit board**

"OPEN" is indicated by the parts not mounted on the circuit board.



**CIRCUIT BOARD NOTES**

**1. Foil and Component sides**

- 1) Foil side (B side) :  
Parts on the foil side seen from foil face (pattern face) are indicated.
- 2) Component side (A side) :  
Parts on the component side seen from component face (parts face) indicated.

**2. Parts location guides**

Parts location are indicated by guide scale on the circuit board.

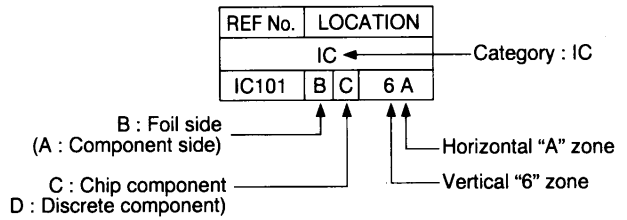

4.1 BOARD INTERCONNECTIONS

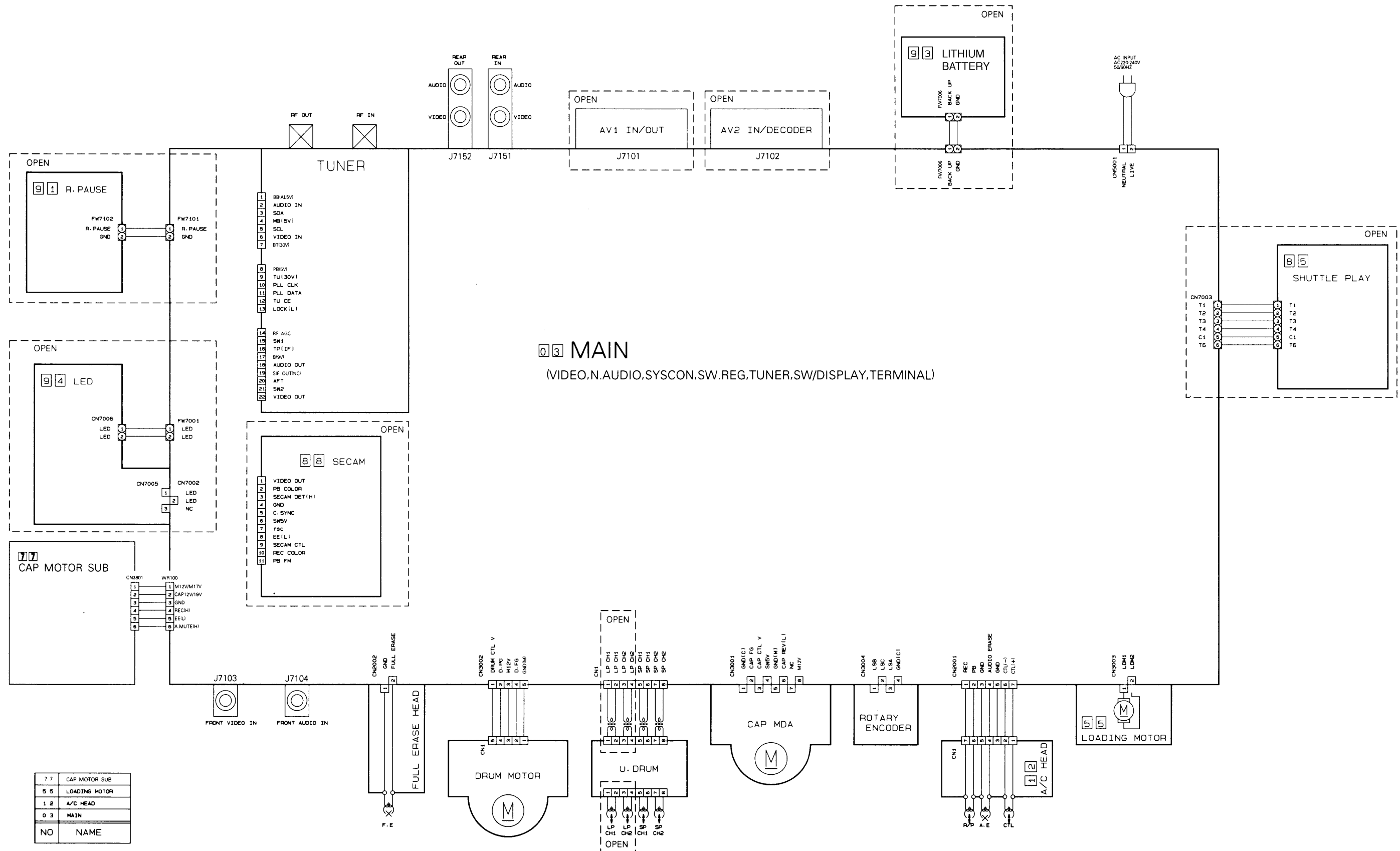

### 4.2 VIDEO/N. AUDIO SCHEMATIC DIAGRAM

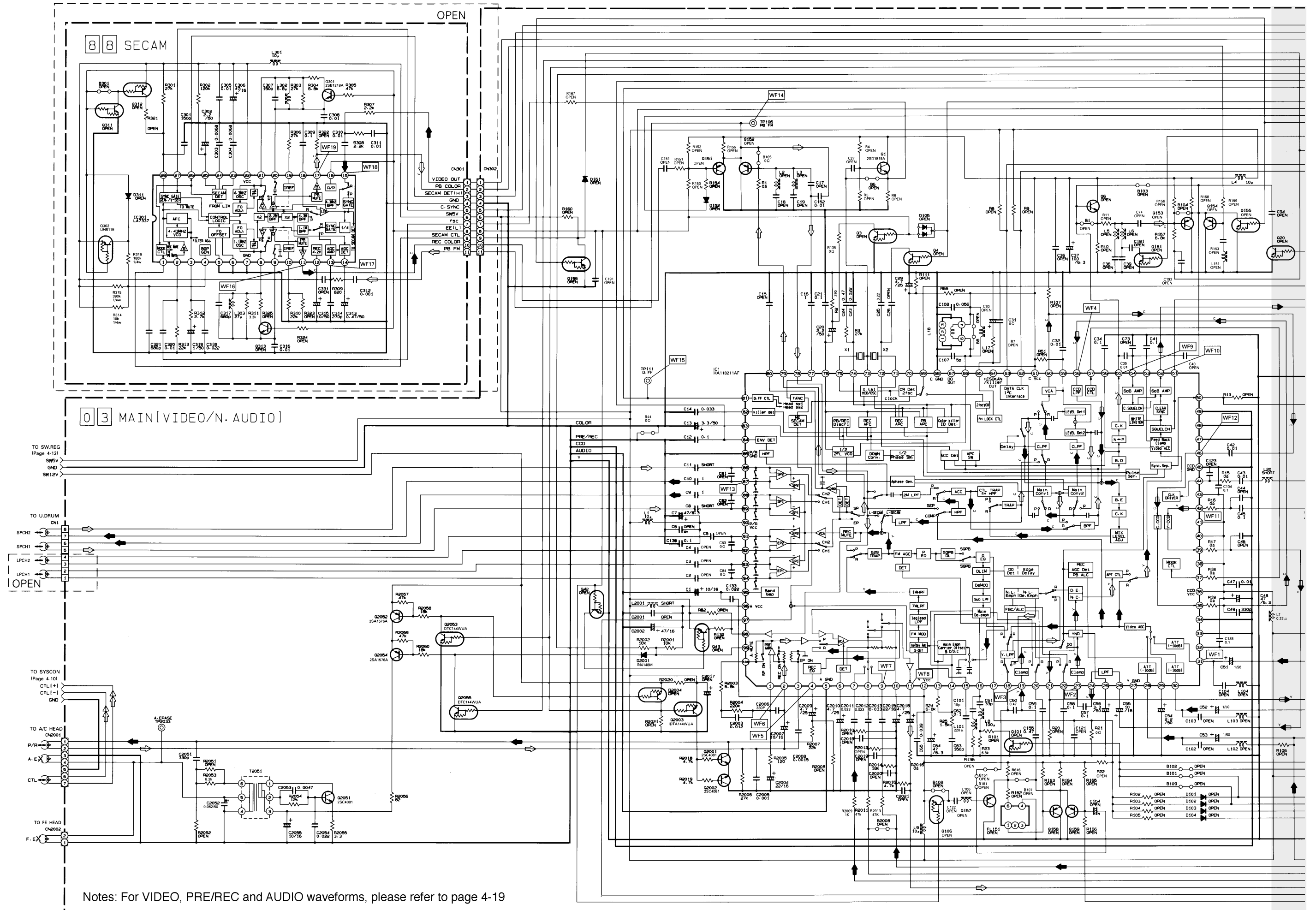

### 4.3 ON SCREEN SCHEMATIC DIAGRAM

#### 03 MAIN (ON SCREEN)

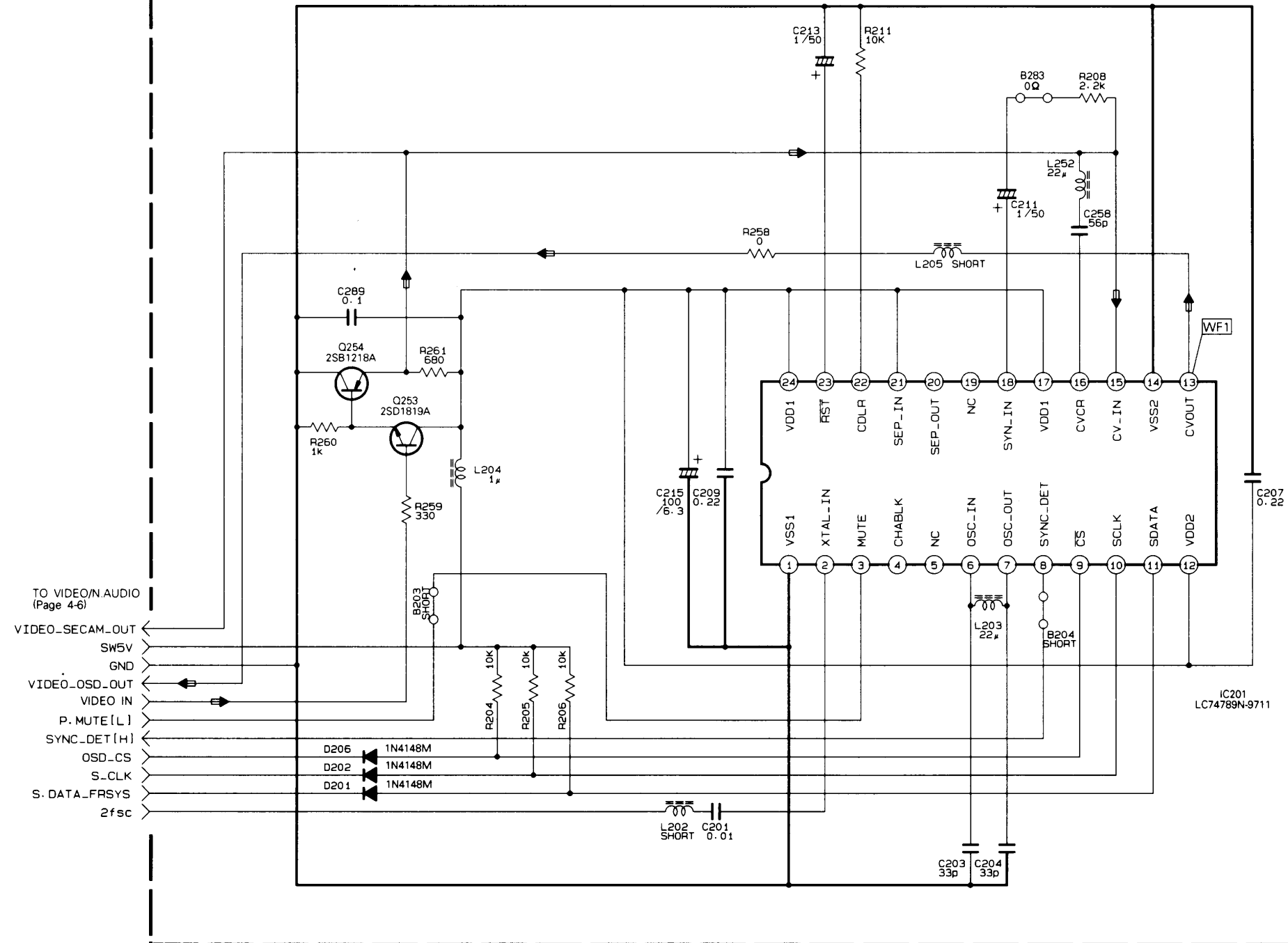
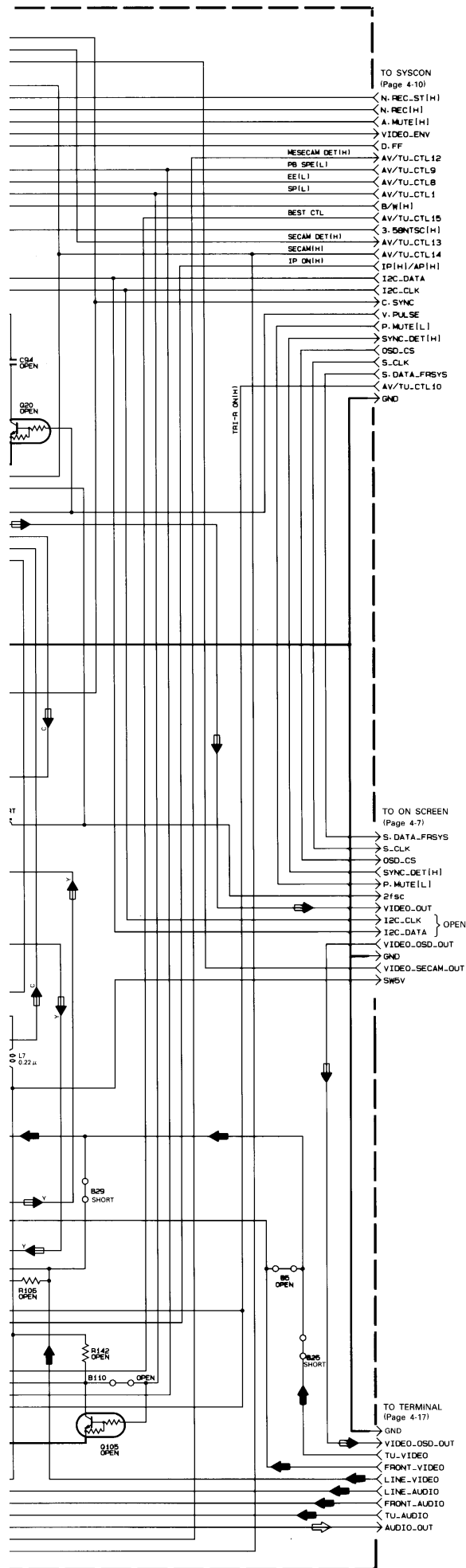

NOTE : For ON SCREEN waveforms, please refer to page4-19.

### 4.4 SYSCON SCHEMATIC DIAGRAM

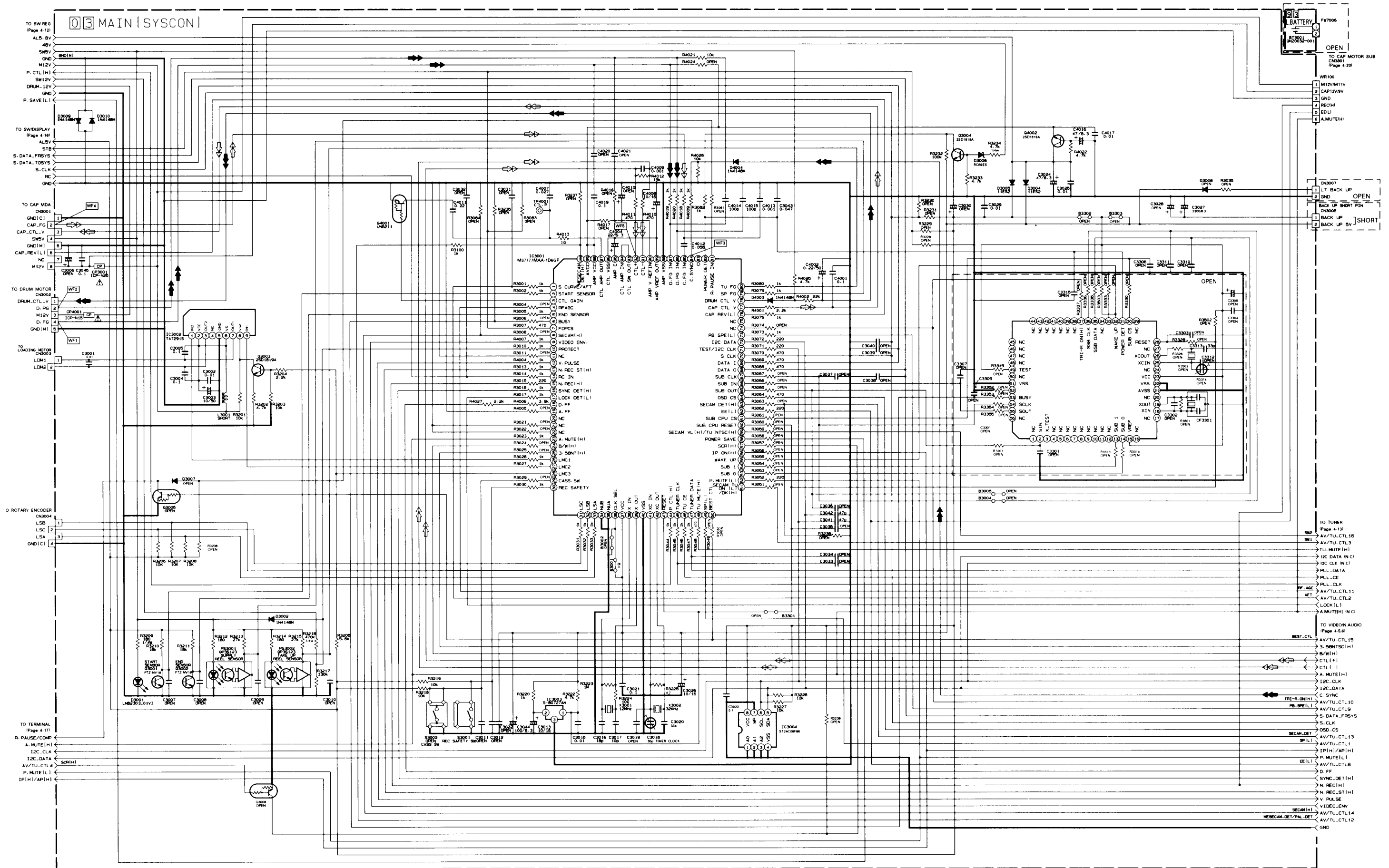

NOTES : 1. For SYSCON waveforms, please refer to page 4-19.  
 2. Be sure to remove the R3229 and install the R3228 (100K) when replacing the SYSTEM CONTROLLER IC3001 and EEPROM IC3004.

### 4.5 SWITCHING REGULATOR SCHEMATIC DIAGRAM

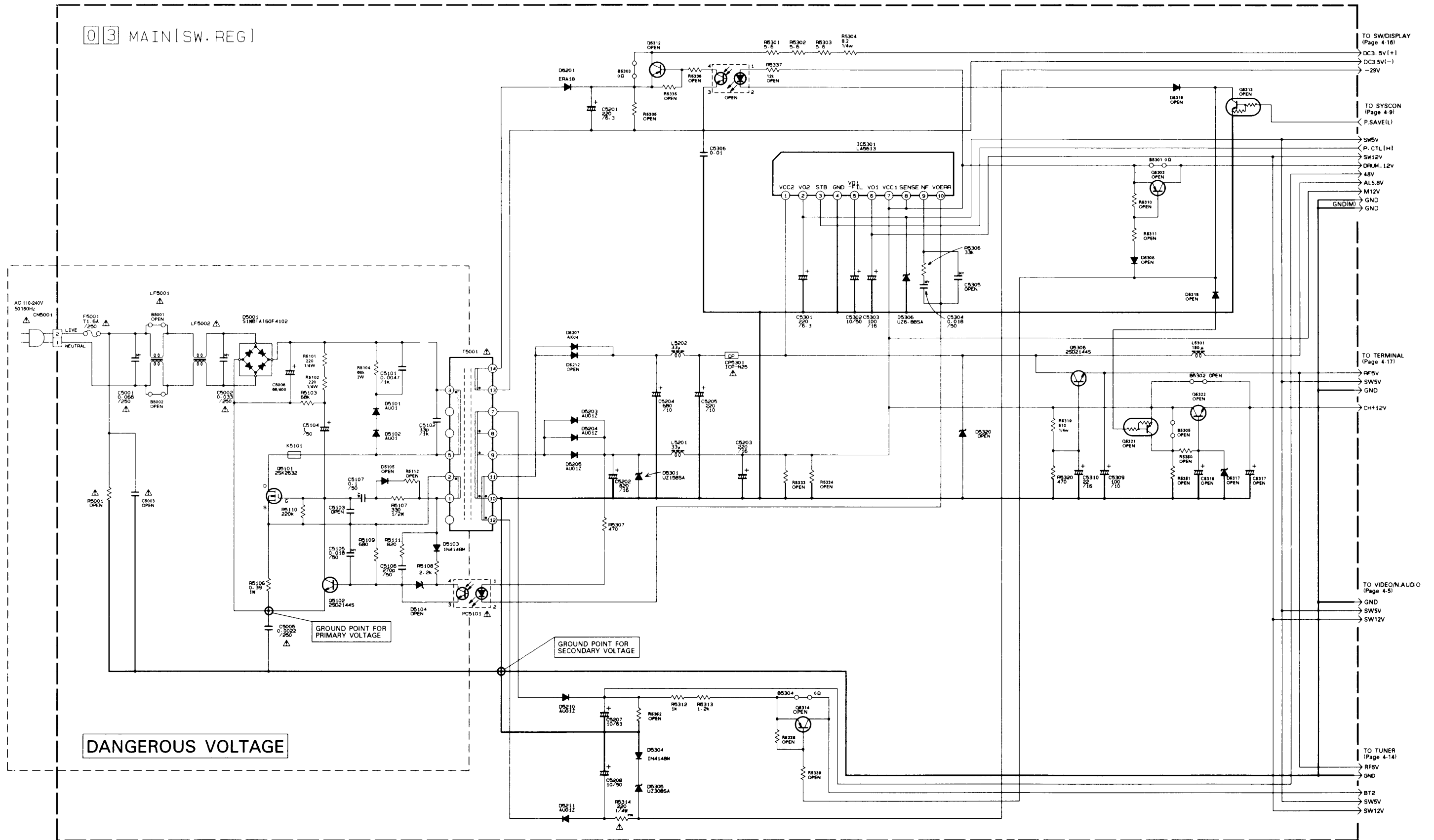

### 4.6 TUNER SCHEMATIC DIAGRAM

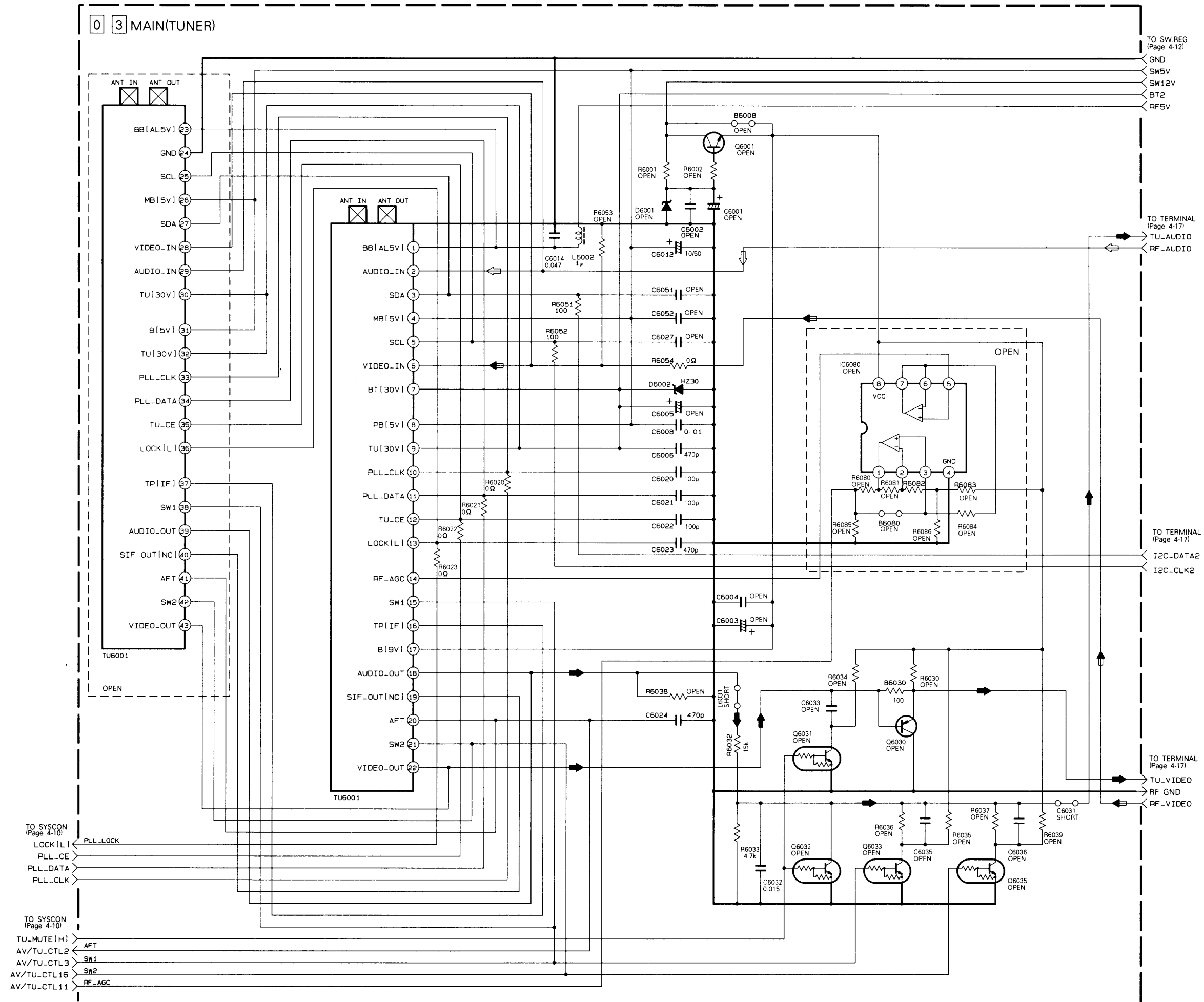



4.7 SW/DISPLAY SCHEMATIC DIAGRAM

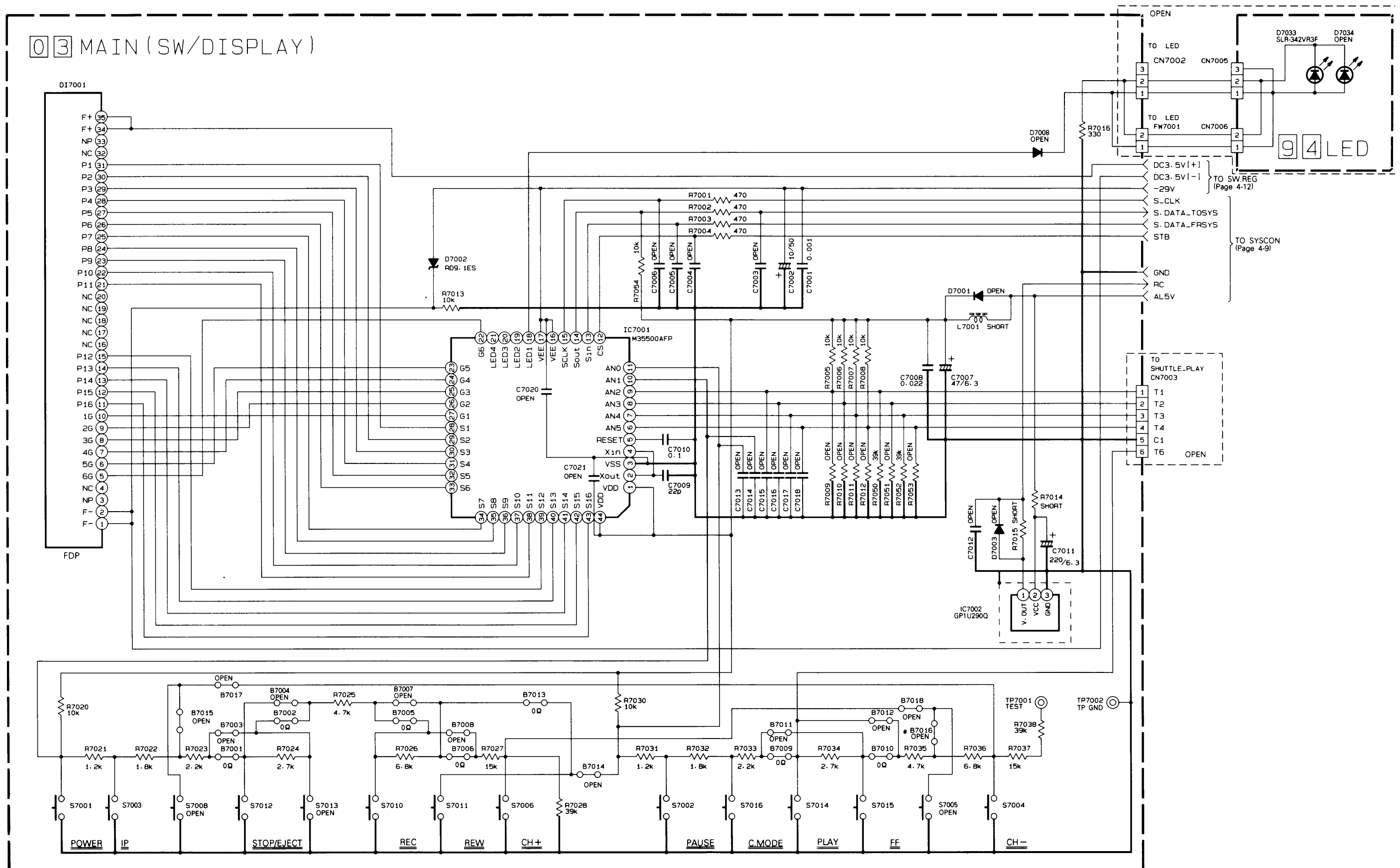

### 4.8 TERMINAL SCHEMATIC DIAGRAM

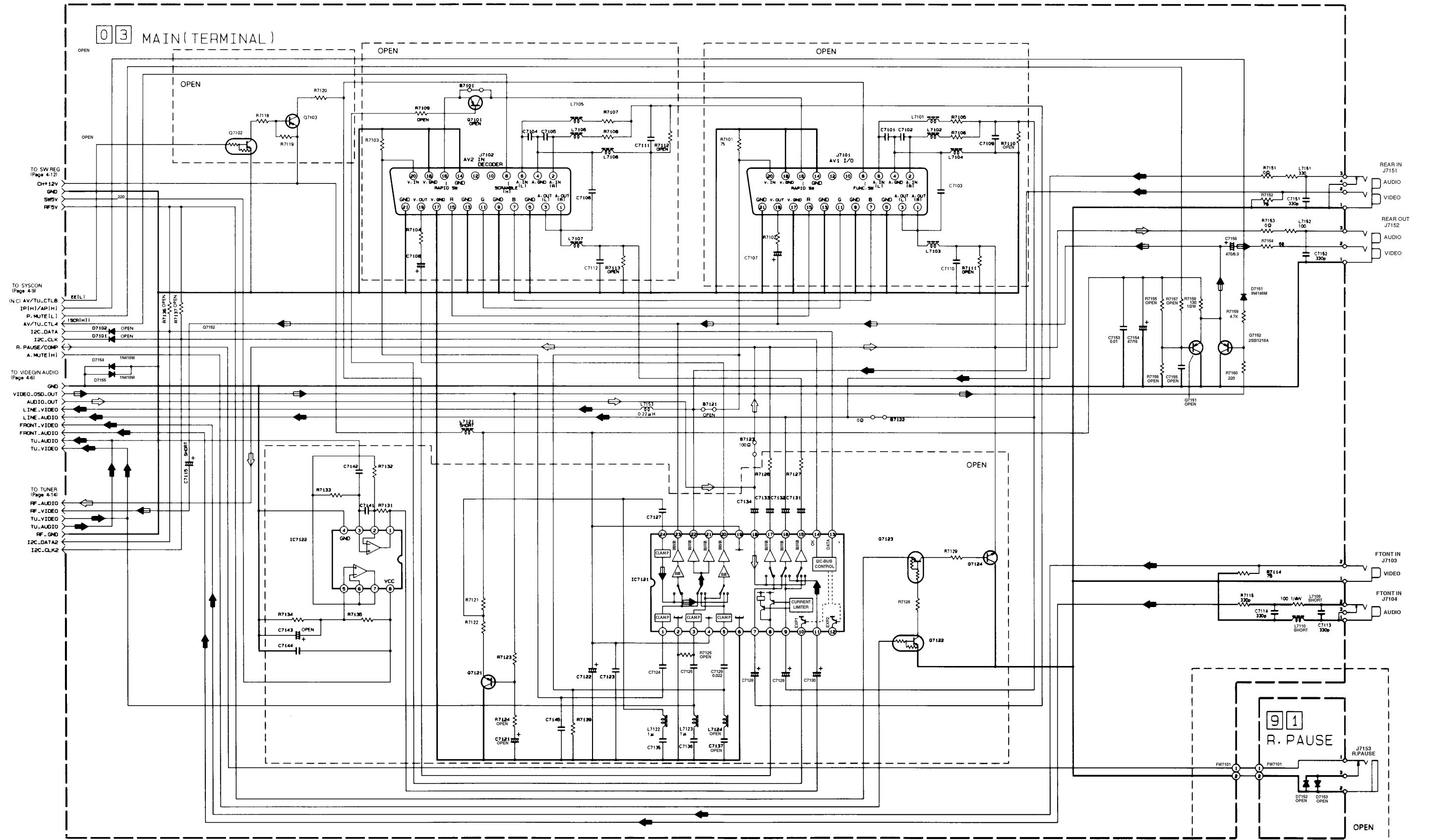

WAVEFORMS

— VIDEO/AUDIO —

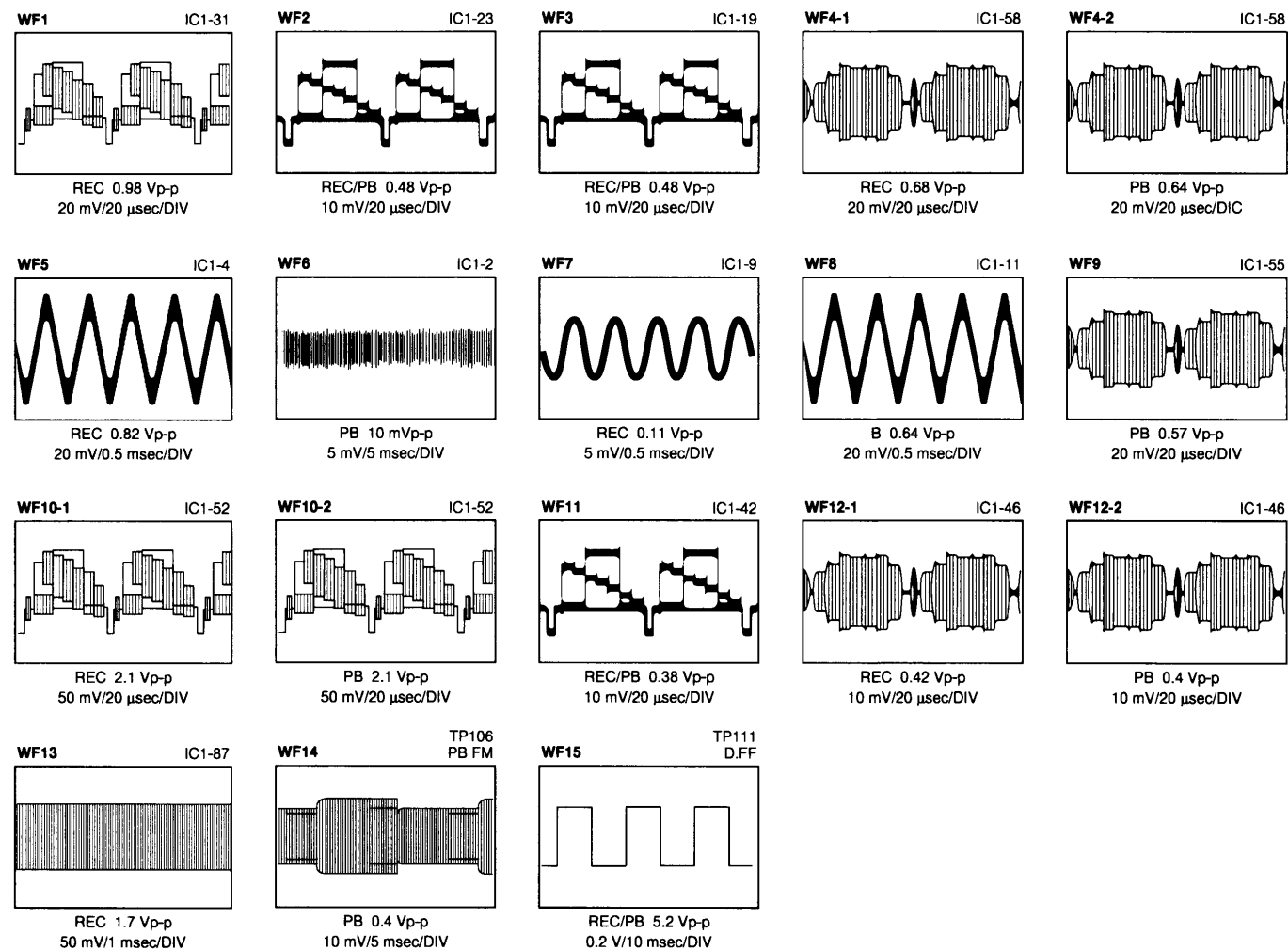

— ON SCREEN —

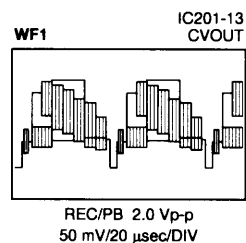

— SYSCON —

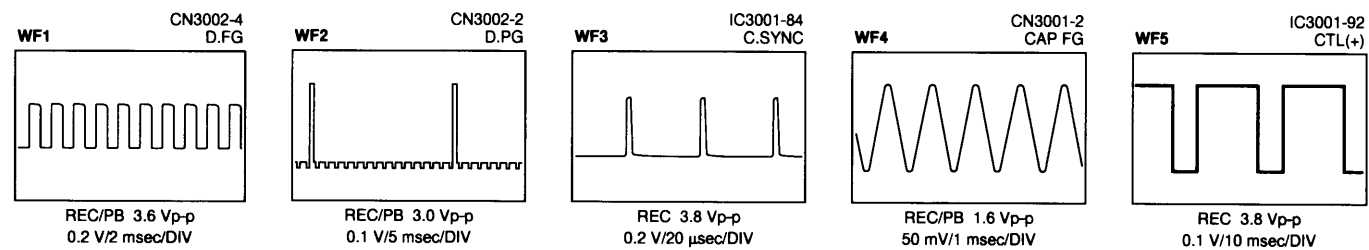

4.9 CAP MOTOR SUB SCHEMATIC DIAGRAM AND CIRCUIT BOARD

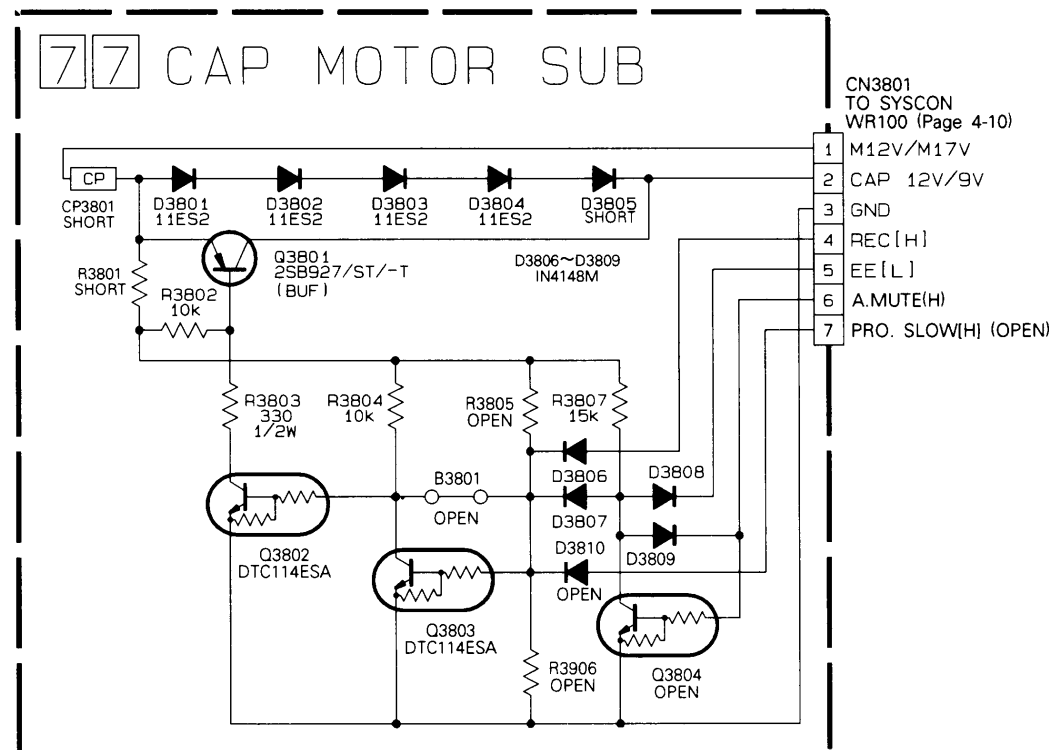

— CAP MOTOR SUB —

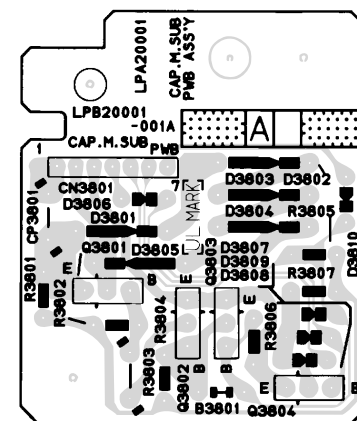

### 4.10 MAIN AND A/C HEAD CIRCUIT BOARDS

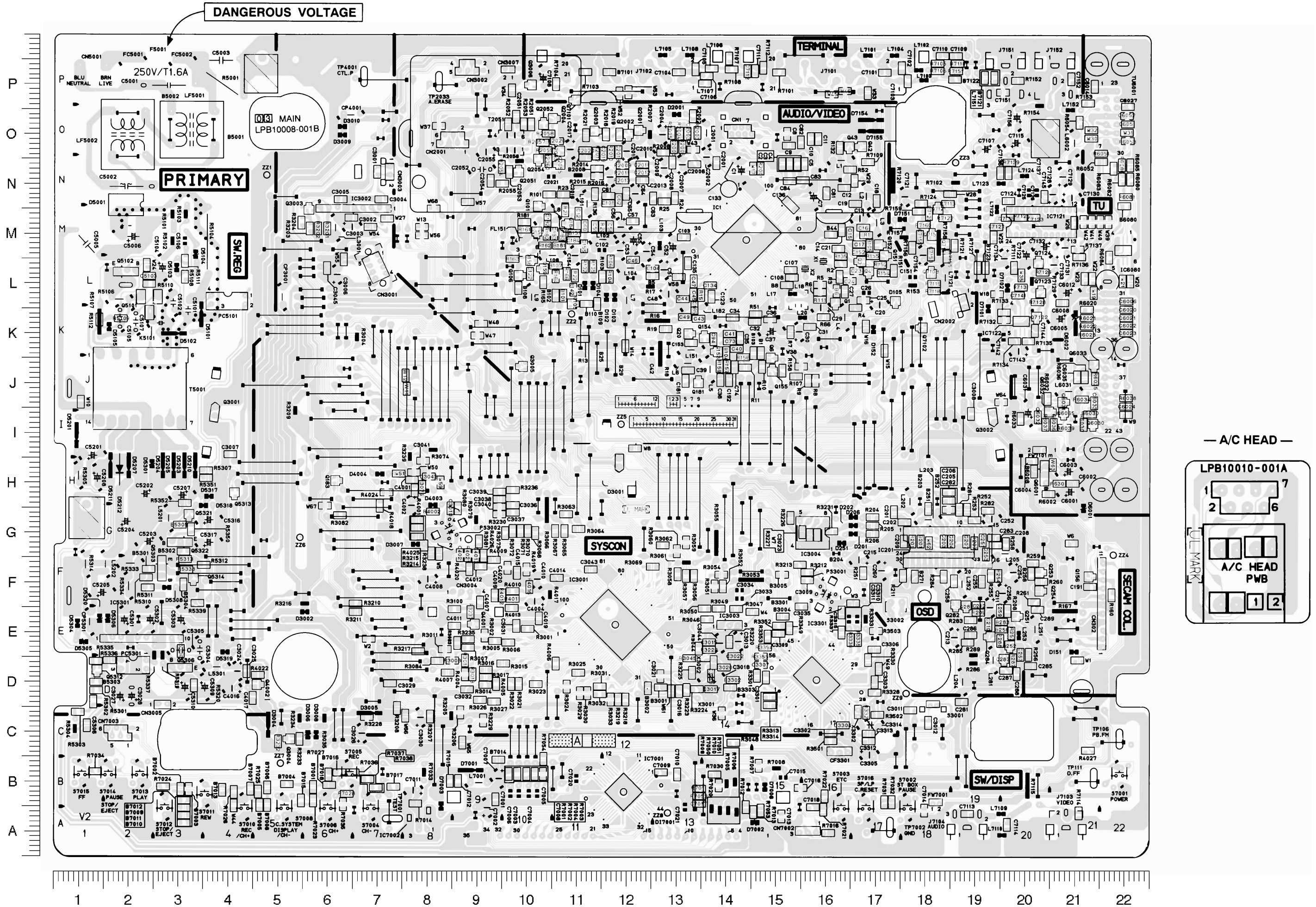

COMPONENT PARTS LOCATION GUIDE <MAIN>

REF.NO.	LOCATION	REF.NO.	LOCATION	REF.NO.	LOCATION	REF.NO.	LOCATION	REF.NO.	LOCATION	REF.NO.	LOCATION	REF.NO.	LOCATION	REF.NO.	LOCATION	
<b>CAPACITOR</b>																
C1	D	C2006	B	C	C6014	B	C	D283	B	C	C	B	C	R2001	B	C
C2	B	C2007	A	D	C6020	A	D	D284	B	C	C	B	C	R2002	B	C
C3	B	C2008	A	D	C6021	A	D	D284	B	C	C	B	C	R2003	B	C
C4	B	C2009	A	D	C6022	A	D	D284	B	C	C	B	C	R2004	B	C
C5	B	C2010	A	D	C6023	A	D	D284	B	C	C	B	C	R2005	B	C
C6	B	C2011	A	D	C6024	A	D	D284	B	C	C	B	C	R2006	B	C
C7	B	C2012	A	D	C6027	A	D	D284	B	C	C	B	C	R2007	B	C
C8	B	C2013	A	D	C6031	A	D	D284	B	C	C	B	C	R2008	B	C
C9	B	C2014	A	D	C6032	A	D	D284	B	C	C	B	C	R2009	B	C
C10	B	C2015	A	D	C6033	A	D	D284	B	C	C	B	C	R2010	B	C
C11	B	C2016	A	D	C6035	A	D	D284	B	C	C	B	C	R2011	B	C
C12	B	C2017	A	D	C6036	A	D	D284	B	C	C	B	C	R2012	B	C
C13	B	C2018	A	D	C6051	A	D	D284	B	C	C	B	C	R2013	B	C
C14	B	C2019	A	D	C6052	A	D	D284	B	C	C	B	C	R2014	B	C
C15	B	C2020	A	D	C7001	A	D	D284	B	C	C	B	C	R2015	B	C
C16	B	C2021	A	D	C7002	A	D	D284	B	C	C	B	C	R2016	B	C
C17	B	C2021	A	D	C7003	A	D	D284	B	C	C	B	C	R2017	B	C
C18	B	C2021	A	D	C7004	A	D	D284	B	C	C	B	C	R2018	B	C
C19	B	C2021	A	D	C7005	A	D	D284	B	C	C	B	C	R2019	B	C
C20	B	C2021	A	D	C7006	A	D	D284	B	C	C	B	C	R2020	B	C
C21	B	C2021	A	D	C7007	A	D	D284	B	C	C	B	C	R2021	B	C
C22	B	C2021	A	D	C7008	A	D	D284	B	C	C	B	C	R2022	B	C
C23	B	C2021	A	D	C7009	A	D	D284	B	C	C	B	C	R2023	B	C
C24	B	C2021	A	D	C7010	A	D	D284	B	C	C	B	C	R2024	B	C
C25	B	C2021	A	D	C7011	A	D	D284	B	C	C	B	C	R2025	B	C
C26	B	C2021	A	D	C7012	A	D	D284	B	C	C	B	C	R2026	B	C
C27	B	C2021	A	D	C7013	A	D	D284	B	C	C	B	C	R2027	B	C
C28	B	C2021	A	D	C7014	A	D	D284	B	C	C	B	C	R2028	B	C
C29	B	C2021	A	D	C7015	A	D	D284	B	C	C	B	C	R2029	B	C
C30	B	C2021	A	D	C7016	A	D	D284	B	C	C	B	C	R2030	B	C
C31	B	C2021	A	D	C7017	A	D	D284	B	C	C	B	C	R2031	B	C
C32	B	C2021	A	D	C7018	A	D	D284	B	C	C	B	C	R2032	B	C
C33	B	C2021	A	D	C7019	A	D	D284	B	C	C	B	C	R2033	B	C
C34	B	C2021	A	D	C7020	A	D	D284	B	C	C	B	C	R2034	B	C
C35	B	C2021	A	D	C7021	A	D	D284	B	C	C	B	C	R2035	B	C
C36	B	C2021	A	D	C7022	A	D	D284	B	C	C	B	C	R2036	B	C
C37	B	C2021	A	D	C7023	A	D	D284	B	C	C	B	C	R2037	B	C
C38	B	C2021	A	D	C7024	A	D	D284	B	C	C	B	C	R2038	B	C
C39	B	C2021	A	D	C7025	A	D	D284	B	C	C	B	C	R2039	B	C
C40	B	C2021	A	D	C7026	A	D	D284	B	C	C	B	C	R2040	B	C
C41	B	C2021	A	D	C7027	A	D	D284	B	C	C	B	C	R2041	B	C
C42	B	C2021	A	D	C7028	A	D	D284	B	C	C	B	C	R2042	B	C
C43	B	C2021	A	D	C7029	A	D	D284	B	C	C	B	C	R2043	B	C
C44	B	C2021	A	D	C7030	A	D	D284	B	C	C	B	C	R2044	B	C
C45	B	C2021	A	D	C7031	A	D	D284	B	C	C	B	C	R2045	B	C
C46	B	C2021	A	D	C7032	A	D	D284	B	C	C	B	C	R2046	B	C
C47	B	C2021	A	D	C7033	A	D	D284	B	C	C	B	C	R2047	B	C
C48	B	C2021	A	D	C7034	A	D	D284	B	C	C	B	C	R2048	B	C
C49	B	C2021	A	D	C7035	A	D	D284	B	C	C	B	C	R2049	B	C
C50	B	C2021	A	D	C7036	A	D	D284	B	C	C	B	C	R2050	B	C
C51	B	C2021	A	D	C7037	A	D	D284	B	C	C	B	C	R2051	B	C
C52	B	C2021	A	D	C7038	A	D	D284	B	C	C	B	C	R2052	B	C
C53	B	C2021	A	D	C7039	A	D	D284	B	C	C	B	C	R2053	B	C
C54	B	C2021	A	D	C7040	A	D	D284	B	C	C	B	C	R2054	B	C
C55	B	C2021	A	D	C7041	A	D	D284	B	C	C	B	C	R2055	B	C
C56	B	C2021	A	D	C7042	A	D	D284	B	C	C	B	C	R2056	B	C
C57	B	C2021	A	D	C7043	A	D	D284	B	C	C	B	C	R2057	B	C
C58	B	C2021	A	D	C7044	A	D	D284	B	C	C	B	C	R2058	B	C
C59	B	C2021	A	D	C7045	A	D	D284	B	C	C	B	C	R2059	B	C
C60	B	C2021	A	D	C7046	A	D	D284	B	C	C	B	C	R2060	B	C
C61	B	C2021	A	D	C7047	A	D	D284	B	C	C	B	C	R2061	B	C
C62	B	C2021	A	D	C7048	A	D	D284	B	C	C	B	C	R2062	B	C
C63	B	C2021	A	D	C7049	A	D	D284	B	C	C	B	C	R2063	B	C
C64	B	C2021	A	D	C7050	A	D	D284	B	C	C	B	C	R2064	B	C
C65	B	C2021	A	D	C7051	A	D	D284	B	C	C	B	C	R2065	B	C
C66	B	C2021	A	D	C7052	A	D	D284	B	C	C	B	C	R2066	B	C
C67	B	C2021	A	D	C7053	A	D	D284	B	C	C	B	C	R2067	B	C
C68	B	C2021	A	D	C7054	A	D	D284	B	C	C	B	C	R2068	B	C
C69	B	C2021	A	D	C7055	A	D	D284	B	C	C	B	C	R2069	B	C
C70	B	C2021	A	D	C7056	A	D	D284	B	C	C	B	C	R2070	B	C
C71	B	C2021	A	D	C7057	A	D	D284	B	C	C	B	C	R2071	B	C
C72	B	C2021	A	D	C7058	A	D	D284	B	C	C	B	C	R2072	B	C
C73	B	C2021	A	D	C7059	A	D	D284	B	C	C	B	C	R2073	B	C
C74	B	C2021	A	D	C7060	A	D	D284	B	C	C	B	C	R2074	B	C
C75	B	C2021	A	D	C7061	A	D	D284	B	C	C	B	C	R2075	B	C
C76	B	C2021	A	D	C7062	A	D	D284	B	C	C	B	C	R2076	B	C
C77	B	C2021	A	D	C7063	A	D	D284	B	C	C	B	C	R2077	B	C
C78	B	C2021	A	D	C7064	A	D	D284	B	C	C	B	C	R2078	B	C
C79	B	C2021	A	D	C7065	A	D	D284	B	C	C	B	C	R2079	B	C
C80	B	C2021	A	D	C7066	A	D	D284	B	C	C	B	C	R2080	B	C
C81	B	C2021	A	D	C7067	A	D	D284	B	C	C	B	C	R2081	B	C
C82	B	C2021	A	D	C7068	A	D	D284	B	C	C	B	C	R2082	B	C
C83	B	C2021	A	D	C7069	A	D	D284	B	C	C	B	C	R2083	B	C
C84	B	C2021	A	D	C7070	A	D	D284	B	C	C	B	C	R2084	B	C
C85	B	C2021	A	D	C7071	A	D	D284	B	C	C	B	C	R2085	B	C
C86	B	C2021	A	D	C7072	A	D	D284	B	C	C	B	C	R2086	B	C
C87	B	C2021	A	D	C7073	A	D	D284	B	C	C	B	C	R2087	B	C
C88	B	C2021	A	D	C7074	A	D	D284	B	C	C	B	C	R2088	B	C
C89	B	C2021	A	D	C7075	A	D	D284	B	C	C	B	C	R2089	B	C
C90	B	C2021	A	D	C7076	A	D	D284	B	C	C	B	C	R2090	B	C
C91	B	C2021	A	D	C7077	A	D	D284	B	C	C	B	C	R2091	B	C
C92	B	C2021	A	D	C7078	A	D	D284	B	C	C	B	C	R2092	B	C
C93	B	C2021	A	D	C7079	A	D	D284	B	C	C	B	C	R2093	B	C
C94	B	C2021	A	D	C7080	A	D	D284	B	C	C	B	C	R2094	B	C
C95	B	C2021	A	D	C7081	A	D	D284	B	C	C	B	C	R2095	B	C
C96	B	C2021	A	D	C7082	A	D	D284	B	C	C	B	C	R		



**GRID ASSIGNMENT**

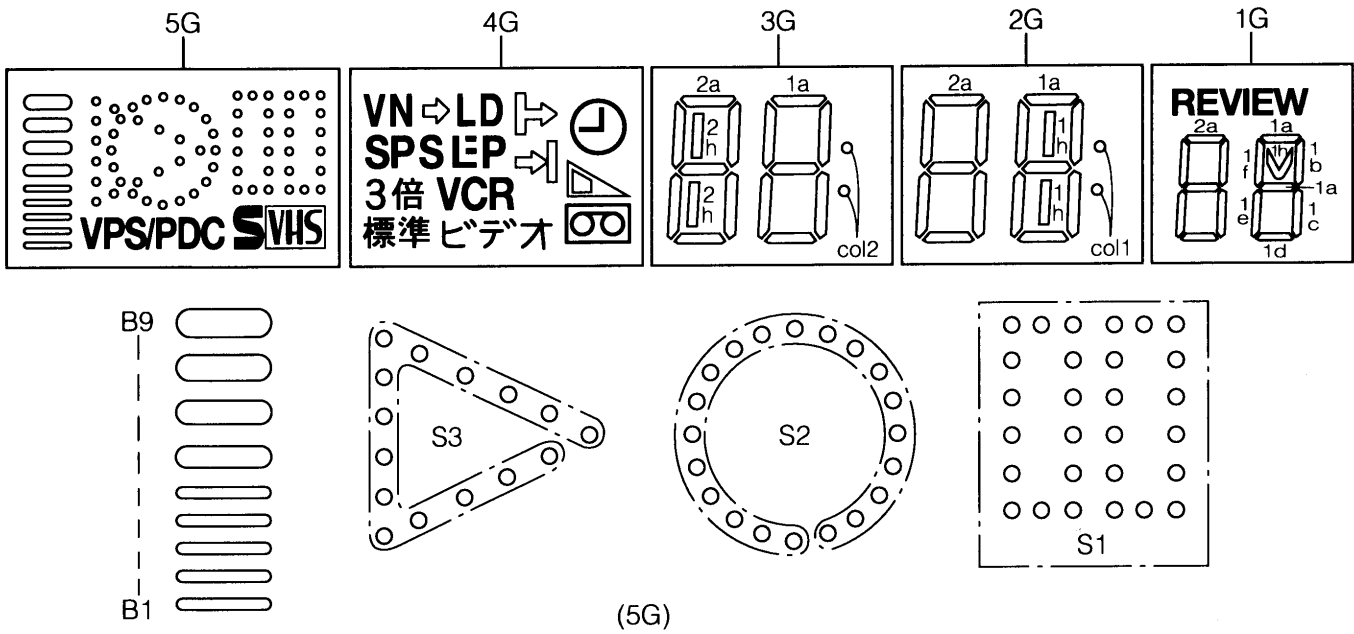

**ANODE CONNECTION**

	5G	4G	3G	2G	1G
P 1	S2	⇨	1a	1a	1a
P 2	S1	⇨⇩	1b	1b	1b
P 3	S3	3倍	1f	1f	1f
P 4	VPS/PDC	標準	1g	1g	1g
P 5	SVHS	⌚	1c	1c	1c
P 6	—	▴	1e	1e	1e
P 7	—	⊞	1d	1d	1d
P 8	B9	VCR	col2	1h	1h
P 9	B8	ビデオ	2a	2a	2a
P10	B7	⇨	2b	2b	2b
P11	B6	VN	2f	2f	2f
P12	B5	LD	2g	2g	2g
P13	B4	SP	2c	2c	2c
P14	B3	S <sub>(SEP)</sub>	2e	2e	2e
P15	B2	= <sub>(SEP)</sub>	2d	2d	2d
P16	B1	LP <sub>(SEP)</sub>	2h	col1	REVIEW

4.12 REMOTE CONTROL SCHEMATIC DIAGRAM

- NOTES:  
 1. All parts shown in this schematic are critical for safety.  
 2. This schematic is only for reference.  
 Avoid replacing individual parts.  
 Replace the entire unit only.

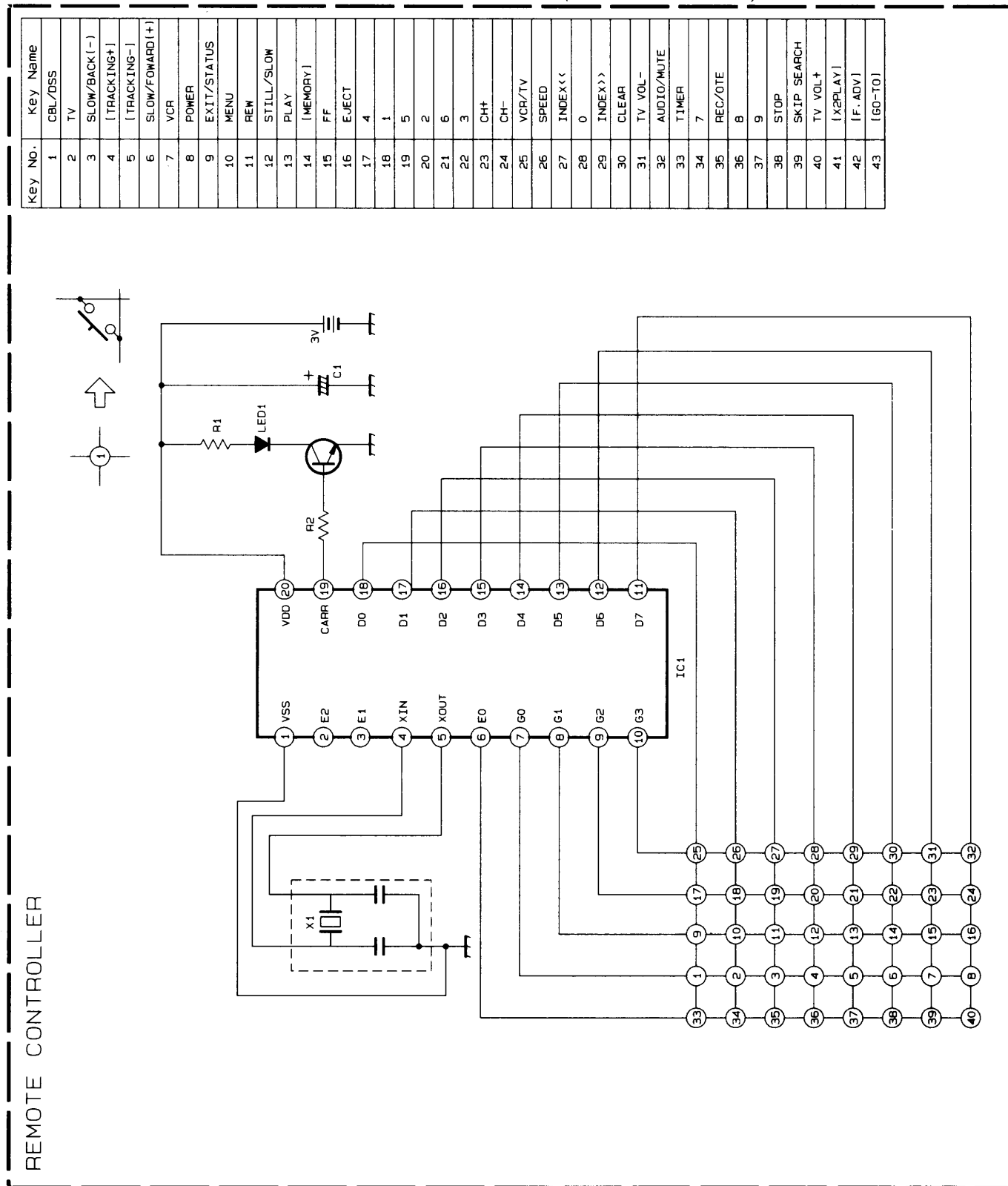

4.13 VOLTAGE CHARTS

<VIDEO/AUDIO>

MODE PIN NO.	REC	PLAY
IC1		
1	2.4	2.4
2	2.4	2.4
3	0	0
4	2.5	2.5
5	0	0
6	0.4	0.9
7	2.4	2.4
8	2.4	2.4
9	2.4	2.4
10	2.5	2.5
11	2.5	2.5
12	4.9	4.9
13	1.8	1.6
14	1.8	1.5
15	2.6	2.8
16	2.0	0.8
17	0	0
18	2.2	2.1
19	3.0	3.0
20	2.7	2.7
21	2.4	2.3
22	2.3	2.0
23	3.0	2.9
24	2.1	2.1
25	1.4	1.4
26	2.1	2.1
27	0	0
28	3.0	2.9
29	1.9	1.8
30	2.7	2.8
31	2.8	2.7
32	0	0
33	0	0
34	0	0
35	3.1	3.0
36	5.1	5.0
37	0	0
38	5.1	5.1
39	3.1	3.1
40	5.0	5.1
41	5.1	5.1
42	2.0	2.1
43	5.1	5.0
44	2.6	2.6
45	0	0
46	2.0	2.1
47	0	0

MODE PIN NO.	REC	PLAY
48	0	0
49	0	0
50	0.3	0.3
51	0	0
52	2.4	2.4
53	2.7	2.8
54	1.9	2.0
55	2.1	2.2
56	2.7	2.8
57	0	0
58	3.1	3.2
59	2.8	2.8
60	2.1	2.1
61	5.0	5.0
62	4.9	4.9
63	4.9	4.9
64	-	-
65	1.8	2.0
66	5.0	5.0
67	5.0	5.0
68	0	0
69	2.8	2.7
70	2.6	2.6
71	-	-
72	2.2	2.2
73	-	-
74	2.6	1.0
75	-	-
76	2.5	2.5
77	4.9	4.7
78	2.7	2.8
79	4.1	2.2
80	0	0
81	2.5	2.7
82	1.2	1.2
83	2.5	2.5
84	0	2.8
85	0	0
86	2.1	2.2
87	2.2	2.2
88	2.3	2.2
89	2.3	2.2
90	5.0	5.0
91	0.5	0
92	0.7	0
93	0	0
94	0	0
95	2.8	2.8

MODE PIN NO.	REC	PLAY
96	5.1	5.1
97	0	0
98	2.1	2.4
99	0.6	2.6
100	2.4	2.4
Q2001		
E	-12.0	0
C	0	0
B	-21.3	0.7
Q2002		
E	-12.1	0
C	0	0
B	-21.0	0.7
Q2003		
E	5.1	5.0
C	-21.0	5.0
B	5.1	0
Q2051		
E	0	0
C	8.3	0
B	0.4	0.3
Q2052		
E	11.5	11.6
C	11.4	2.9
B	10.8	11.5
Q2053		
E	0	0
C	0	11.5
B	5.1	0
Q2054		
E	11.4	2.9
C	11.2	0.3
B	10.6	3.0
Q2055		
E	0	0
C	0	2.9
B	5.0	0
CN1		
1	0	0
2	0	0
3	0.5	0
4	0.5	0
5	2.2	2.2
6	2.2	2.2
7	2.1	2.2
8	2.1	2.2
CN2001		
1	0	0

MODE PIN NO.	REC	PLAY
2	0	0
3	0	0
4	0	0
5	0	0
6	2.3	2.4
7	2.5	2.5
CN2002		
1	0	0
2	0	0

<SYSCON>

MODE PIN NO.	REC	PLAY
IC3001		
1	4.7	4.6
2	4.9	4.6
3	5.1	5.1
4	4.8	4.7
5	4.9	4.8
6	4.8	4.8
7	4.1	4.1
8	0	0
9	0	2.6
10	4.7	2.8
11	0	0
12	0	0
13	5.1	0
14	4.8	5.1
15	5.1	0
16	5.1	5.0
17	1.9	0
18	2.7	2.6
19	0	2.4
20	-	-
21	0	0
22	0	0
23	0	0
24	0	0
25	0	0
26	0	0
27	0	0
28	0	0
29	0	0
30	5.1	5.1
31	5.1	4.8

MODE PIN NO.	REC	PLAY
32	5.1	5.1
33	0	0
34	0	0
35	0	0
36	5.1	5.1
37	5.1	5.1
38	-	-
39	-	-
40	0	0
41	-	-
42	-	-
43	5.2	5.1
44	5.1	5.1
45	0	0
46	0	0
47	0	0
48	5.1	5.1
49	0	0
50	0	5.1
51	5.1	5.1
52	5.1	5.1
53	0	0
54	0	0
55	0	0
56	0	0
57	5.1	5.1
58	5.3	5.1
59	0	0
60	0	0
61	4.1	4.1
62	0	5.2
63	0	0
64	1.0	1.0
65	1.0	1.0
66	0.8	0.8
67	5.0	5.0
68	4.5	4.4
69	5.1	5.1
70	4.7	4.7
71	4.9	4.9
72	4.9	4.9
73	5.2	5.2
74	0	0
75	-	-
76	5.1	5.1
77	2.5	2.5
78	1.3	1.3
79	-	-

<SWITCHING REGULATOR>

MODE PIN NO.	REC	PLAY
80	-	-
81	0	0
82	0	0
83	0	1.2
84	0.7	0.7
85	2.4	2.5
86	0.7	0.5
87	1.9	1.9
88	1.6	0
89	2.4	2.5
90	2.4	2.5
91	2.0	2.5
92	3.0	2.5
93	2.3	2.4
94	2.5	2.4
95	2.4	2.4
96	2.4	2.5
97	2.3	2.4
98	4.9	4.9
99	4.9	4.9
100	0	0
IC3002		
1	0	0
2	12.3	12.3
3	0.7	0.5
4	-	-
5	0	0
6	12.3	12.3
7	0	0
8	12.3	12.3
9	0	0
IC3003		
1	5.2	5.2
2	5.1	5.1
3	0	0
IC3004		
1	0	0
2	0	0
3	0	0
4	0	0
5	5.0	5.0
6	5.0	5.0
7	0	0
8	5.2	5.2
Q3001		
E	0	0
C	5.0	4.8
B	-	-

MODE PIN NO.	REC	PLAY
Q3002		
E	0	0
C	5.0	4.9
B	-	-
Q3003		
E	0	0
C	12.3	12.3
B	0	0
Q3004		
E	0	0
C	0	0
B	0.7	0.7
Q4001		
E	0	0
C	0	0
B	5.1	5.1
Q4002		
E	4.9	4.9
C	5.8	5.8
B	5.6	5.6
CN3001		
1	0	0
2	2.5	2.5
3	2.4	2.4
4	5.1	5.1
5	0	0
6	5.1	5.1
7	-	-
8	12.3	12.3
CN3002		
1	1.5	1.5
2	0.4	0.4
3	11.6	11.6
4	1.9	1.9
5	0	0
CN3003		
1	0	0
2	0	0
CN3004		
1	5.2	5.2
2	5.2	5.2
3	0	0
4	0	0
CN3005		
1	5.2	5.2
2	5.1	5.1

MODE PIN NO.	REC	PLAY
IC5301		
1	6.1	6.1
2	5.1	5.1
3	4.9	4.9
4	0	0
5	12.3	12.3
6	11.6	11.6
7	12.3	12.3
8	12.3	12.3
9	1.3	1.3
10	11.1	11.1
Q5101		
S	-	-
D	113.4	113.4
G	-	-
Q5102		
E	-	-
C	-	-
B	-	-
Q5306		
E	5.3	5.2
C	6.1	6.1
B	5.9	5.9

<ON SCREEN>

MODE PIN NO.	REC	PLAY
IC201		
1	0	0
2	2.7	2.7
3	5.0	5.0
4	0	0
5	0	0
6	2.5	2.5
7	2.5	2.5
8	5.0	5.0
9	1.6	1.6
10	4.6	4.6
11	4.8	4.9
12	5.0	5.0
13	2.4	2.4
14	0	0
15	2.3	2.4
16	0.4	0.5
17	5.0	5.1

MODE PIN NO.	REC	PLAY
18	2.9	3.0
19	0	0
20	5.1	5.0
21	5.0	5.0
22	3.7	3.7
23	5.0	5.0
24	5.0	5.0
Q253		
E	1.8	1.8
C	5.1	5.1
B	2.4	2.4
Q254		
E	2.4	2.4
C	0	0
B	1.8	1.8

<SW/DISPLAY>

MODE PIN NO.	REC	PLAY
C7001		
1	5.2	5.2
2	2.1	2.1
3	0	0
4	2.1	2.1
5	5.1	5.1
6	4.1	4.1
7	5.2	5.1
8	5.1	5.1
9	5.1	5.1
10	4.6	4.5
11	5.1	5.1
12	4.1	4.1
13	4.5	4.5
14	5.1	5.1
15	4.7	4.7
16	-28.8	-28.7
17	-28.8	-28.7
18	-28.5	-28.4
19	-	-
20	-	-
21	-	-
22	-	-
23	-	-
24	-	-
25	-	-
26	-	-
27	-	-

MODE PIN NO.	REC	PLAY
28	-	-
29	-	-
30	-	-
31	-	-
32	-	-
33	-	-
34	-	-
35	-	-
36	-	-
37	-	-
38	-	-
39	-	-
40	-	-
41	-	-
42		



4.14 SYSTEM CONTROL BLOCK DIAGRAM

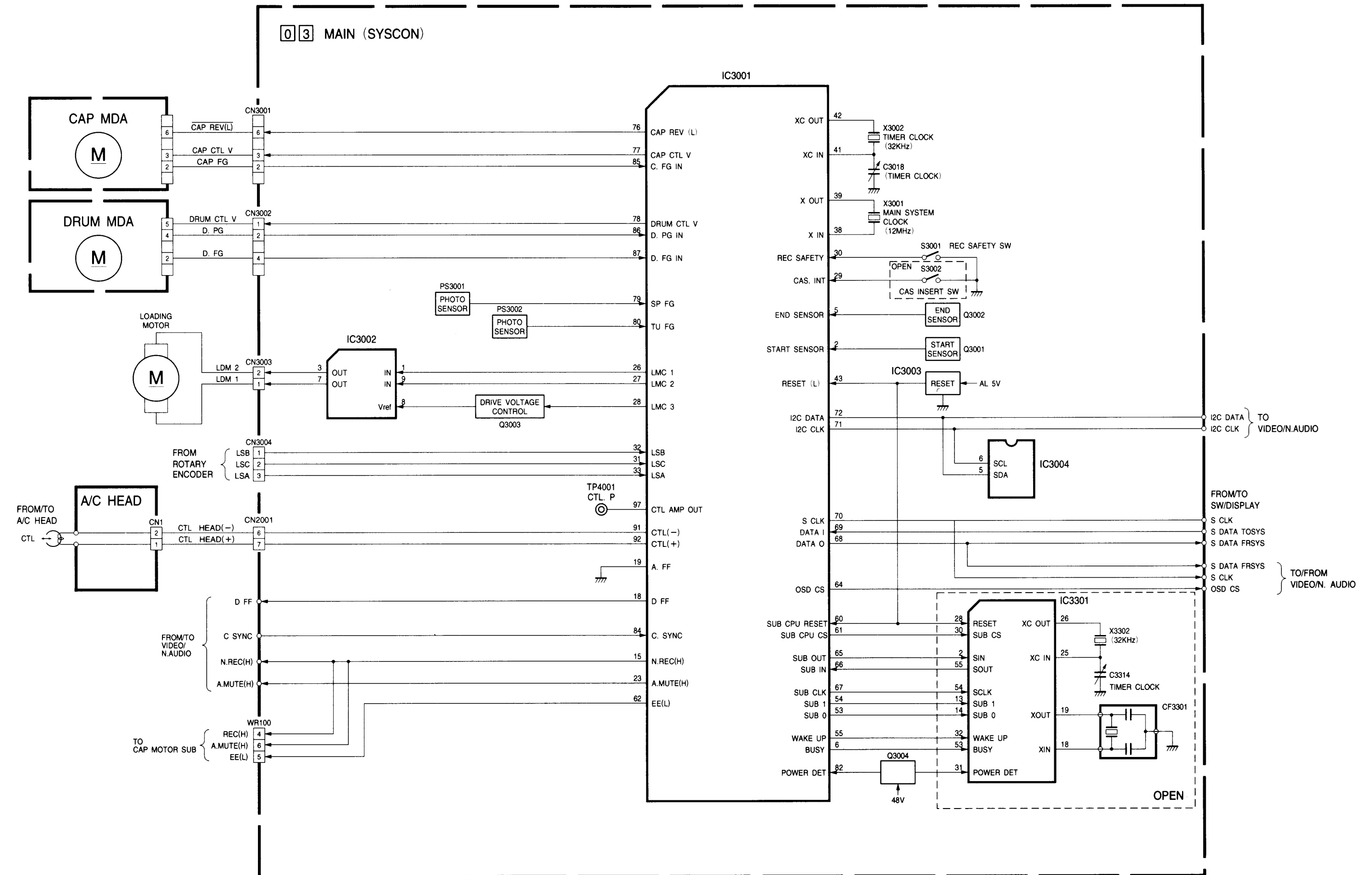



### 4.16 AUDIO BLOCK DIAGRAM

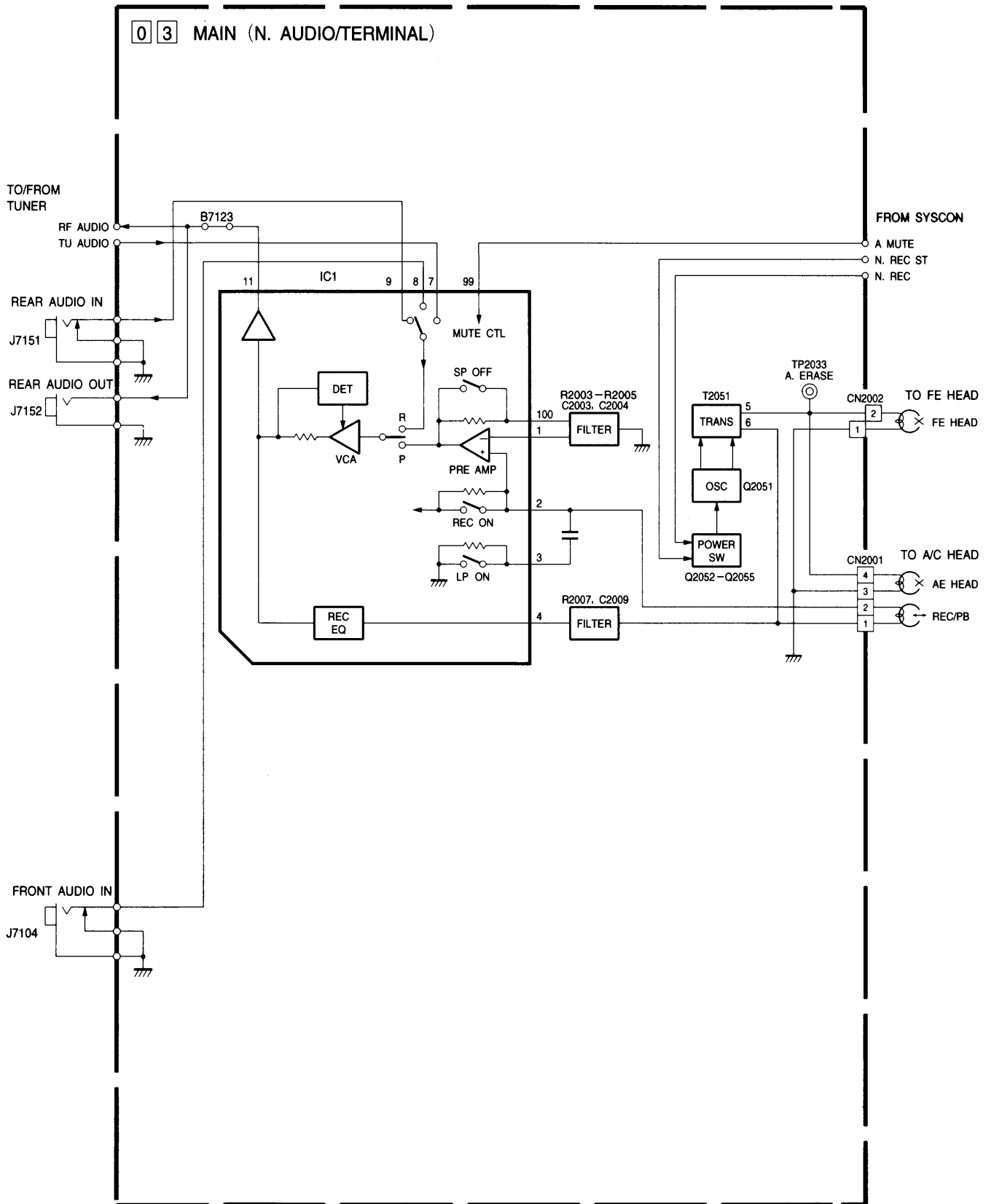





Ersatzteilliste  
Spare Parts List

7 / 98

GRUNDIG

VIDEO

GV 819 M

SACH-NR. / PART NO.: 75866 410 0000  
BESTELL-NR. / ORDER NO.: G.MG 7900

POS. NR. POS. NO.	ABB. FIG.	SACHNUMMER PART NUMBER	ANZ. QTY.	BEZEICHNUNG DESCRIPTION <b>(D)</b>	DESCRIPTION <b>(GB)</b>
		75866 410 0000		GV 819 M KEIN E-TEIL	NO SPARE PART
0004.000	2	75988 324 5300		LADESTANGE (S) KPL.	POLE BASE ASSY (S)
0005.000	2	75988 324 5400		LADESTANGE (T) KPL.	POLE BASE ASSY (T)
0008.000	2	75988 324 5500		HEBEL DAEMPfung	TENSION ARM ASSY
0009.000	2	75988 324 5600		FEDER DAEMPfung	TENSION SPRING
0011.000	2	75988 324 5700		BREMSE HAUPT(AUFNAHME)	MAIN BRAKE ASSY (TAKE UP)
0013.000	2	75988 324 5800		BREMSE HAUPT(LADEN)	MAIN BRAKE ASSY (SUPPLY)
0016.000	2	75988 323 7300		CAPSTAN MOTOR	CAPSTAN MOTOR
0051.000	2	75988 324 5900		ARM LADE	LOADING ARM
0054.000	2	75988 324 6000		RAD SCHNECKE	WORM GEAR
0055.000	2	75988 324 6100		RAD KURVE	CTL CAM
0056.000	2	75988 324 6200		HEBEL AUFNAHME	T.U.P LEVER
0059.000	2	75988 324 6300		BREMSE KPL.	C. BRAKE ASSY
0060.000	2	75988 324 6400		SCHIEBER STEUERUNG	CTL. PLATE
0061.000	2	75988 324 6500		ZAHNRAD/DIRECT GEAR	CLUTCH UNIT
0066.000	2	75988 324 6600		KUPPLUNGSEINHEIT	ROTARY ENCODER
0067.000	2	75988 324 6700		SCHALTER FUNKTIONSWAHL	CHANGE LEVER
0068.000	2	75988 323 7100		RIEMEN BELT	
0069.000	2	75988 324 6800		ARM WECHSEL	CHANG LEVER
0071.000	2	75988 324 6900		SCHEIBE SLIT WSHER	
0101.000	2	75988 324 7000		ARM LEERLAUF KPL.	IDLER ARM ASSY
0102.000	2	75988 324 7100		HEBEL LEERLAUF	IDLER LEVER
0106.000	2	75988 324 7200		BREMSE(T) KPL.	BRAKE (T) CPL
0108.000	2	75988 324 7300		BREMSE KPL.	BRAKE CPL
0115.000	2	75988 324 7400		RAD ANTRIEB	DRIVE GEAR
0116.000	2	75988 324 7500		RAD SCHALTUNG	RELAY GEAR
0123.000	2	75988 324 7600		ROLLE FUEHRUNG	P. ROLLER GUIDE
0151.000	2	75988 324 7700		RAD LADEARM (T)	LOADING ARM GEAR (T)
0152.000	2	75988 324 7800		RAD LADEARM (S)	LOADING ARM GEAR (S)
0171.000	2	75988 323 7400		LADEMOTOR	LOADING MOTOR
0174.000	2	75988 324 7900		RAD ANTRIEB	DRIVE GEAR
0175.000	2	75988 323 7500		RIEMEN BELT	
0191.000	2	75988 323 7600		LOESCHKOPF	ERASE HEAD
0211.000	2	75988 324 8000		ARM ANTRIEB	DRIVE ARM
0251.000	2	75988 324 8100		RAD AUSWURF (1)	LIMIT GEAR (1)
0252.000	2	75988 324 8200		RAD AUSWURF (2)	LIMIT GEAR (2)
0306.000	2	75988 323 9000		FERNBEDIENUNG	REMOTE CONTROL
0306.A	2	75988 323 9100		BATTERIEDECKEL FERNBEDIENUNG	BATTERY LID REMOTE CONTROL
0550.000	△ 1	75988 323 9200		FRONTPLATTE KPL	FRONTPANEL ASSY
0550.A	1	75988 323 9900		KLAPPE KASSETTENFACH	LIFT FLAP
0550.B	1	75988 034 0400		DREHFEDER	TORSION SPRING
0559.A	1	75988 323 7000		KOPFRAD/HEAD WHEEL	
0559.B	1	75988 323 9400		SCANNERS/SCANNER	
0559.H	1	75988 324 4500		STATOR	
0560.000	△ 1	75988 324 4600		BODEN	BOTTOM CHASSIS
0571.000	△ 1	75988 323 2100		NETZKABEL	POWER CABLE
0575.000	1	75988 324 4800		OEFFNER TUER	DOOR OPEN
0578.000	1	75988 323 7200		REINIGUNG/SHEBEL KPL	CLEANER LEVER CPL
0578.A	1	75988 324 4900		ROLLE REINIGUNG	CLEANER ROLLER
0578.B	1	75988 324 5000		REINIGER/CLEANER	
0578.C	1	75988 324 5100		ARM REINIGUNG	CLEANER ARM
		72010 534 2500		BEDIENUNGSANLEITUNG GB/CH	OPERATING INSTRUCTIONS GB/CH
		72010 534 2600		BEDIENUNGSANLEITUNG RUS/AB	OPERATING INSTRUCTIONS RUS/AB
		72010 534 0000		SERVICE MANUAL D/GB	SERVICE MANUAL D/GB

Btx \*32700#

ÄNDERUNGEN VORBEHALTEN / SUBJECT TO ALTERATION

POS. NR. SACHNUMMER BEZEICHNUNG  
POS. NO. PART NUMBER DESCRIPTION

CP 3001	△	75981 309 7000	SCHUTZSCHALTUNG ICP-N25
CP 4001	△	75981 309 4000	SCHUTZSCHALTUNG ICP-N15
CP 5301	△	75981 309 7000	SCHUTZSCHALTUNG ICP-N25 CIRCUIT PROTECTOR

D 5101 75981 307 7500 DIODE 1 SR 153 400 T 2

F 5001 △ 83156 190 0300 SI 5X20 T1,6A L 250V/FUSE

IC 0001	75988 323 7700	IC HA118211AF
IC 0201	75988 323 7800	IC LC74789N9711
IC 3001	75988 323 7900	IC M37777MAA3B1GPIC
IC 3003	75988 323 8100	IC S80727ANZ
IC 3004	75988 323 8200	IC ST24C02FB6
IC 5301	75988 323 8300	IC LA5613
IC 7001	75988 323 8400	IC M35500BFP
IC 7002	75988 323 8500	IC GP1U290Q

LF 5001 △ 75988 323 8600 LINE FILTER

LF 5002 △ 75988 323 8700 LINE FILTER

PC 5101 △ 75988 323 8900 OPTOKOPPLER/PH COUPLER

Q 3001 75988 324 8300 TRANSISTOR PHOTO

S 3001 75988 323 9800 SCHALTER, SICHERHEIT

SWITCH SAFETY

S 7001 75988 323 8800 SCHALTER TAKT, NETZ/POWER

S 7002 75988 323 8800 SCHALTER TAKT, PAUSE/STILL

S 7003 75988 323 8800 SCHALTER TAKT, IP

S 7004 75988 323 8800 SCHALTER TAKT, CH

S 7006 75988 323 8800 SCHALTER TAKT, CH +

S 7010 75988 323 8800 SCHALTER TAKT, REC

S 7011 75988 323 8800 SCHALTER TAKT, REW

S 7012 75988 323 8800 SCHALTER TAKT, STOP (EJECT)

S 7014 75988 323 8800 SCHALTER TAKT, PLAY

S 7015 75988 323 8800 SCHALTER TAKT, FF

S 7016 75988 323 8800 SCHALTER TAKT, C. MODE

T 5001 △ 75988 323 9600 TRAF0

TB 0001 △ 75988 323 9700 BEDIENPLATTE/  
TERMINAL BOARD

TU 6001 △ 75988 323 9500 TUNER

WR 1 75988 324 5200 FLEXIBLE LEITUNG, KOPF/  
FLEXIBLE CABLE, HEAD

Es gelten die Vorschriften und Sicherheitshinweise gemäß dem Service Manual "Sicherheit", Sach-Nummer 72010 800 0000, sowie zusätzlich die eventuell abweichenden, landesspezifischen Vorschriften!

Btx \*32700#



The regulations and safety instructions shall be valid as provided by the "Safety" Service Manual, part number 72010 800 0000, as well as the respective national deviations.

ÄNDERUNGEN VORBEHALTEN / SUBJECT TO ALTERATION